



Single-Phase Emergency Lighting Inverter Installation and Operation Manual

Mini Power Wave, 500-2700 Watts Indoor Lighting Inverter

Sales

Email: sales@onlinepower.com

Sales: (800) 227-8899

Service

Email: Service@800pwrsvc.com

Service: (800-797-7782)

Due to continuous product improvement, this document is subject to change without prior notice.

Document No.: 105-MAN, Rev. C

Notice of Rights

This document contains proprietary and confidential information of OnLine Power. No part of this manual may be reproduced, copied, translated, or transmitted, in any form or by any means, without the prior written permission of the manufacturer.

In consideration of the receipt of this document, the recipient agrees not to copy any of its contents, nor to disclose them to or allow them to be used by any person not currently a company employee or an employee of the recipient having a need to know, without the express written consent of the company, and further agrees to surrender this document to the company when the reason for its receipt has terminated.

Notice of Liability

The information provided in this manual is intended to be accurate and reliable. However, the manufacturer assumes no responsibility for its use, nor for any infringement of the rights of third parties which may result from its use. THIS DOCUMENT IS PROVIDED "AS IS" AND ANY EXPRESS OR IMPLIED WARRANTIES, INCLUDING, BUT NOT LIMITED TO, THE IMPLIED WARRANTIES OF MERCHANTABILITY AND FITNESS FOR A PARTICULAR PURPOSE ARE DISCLAIMED. IN NO EVENT SHALL ABOVE COMPANY BE LIABLE FOR ANY DIRECT, INDIRECT, INCIDENTAL, SPECIAL, EXEMPLARY, OR CONSEQUENTIAL DAMAGES (INCLUDING, BUT NOT LIMITED TO, PROCUREMENT OF SUBSTITUTE GOODS OR SERVICES; LOSS OF USE, DATA, OR PROFITS; OR BUSINESS INTERRUPTION) HOWEVER CAUSED AND ON ANY THEORY OF LIABILITY, WHETHER IN CONTRACT, STRICT LIABILITY, OR TORT (INCLUDING NEGLIGENCE OR OTHERWISE) ARISING IN ANY WAY OUT OF THE USE OF THIS DOCUMENT, EVEN IF ADVISED OF THE POSSIBILITY OF SUCH DAMAGE.

Trademarks

All trademarks and registered trademarks are the property of their respective owners.

Emergency Lighting Inverter Installation and Operation Manual

Document No.: 105-MAN, Rev. C
October 27, 2025

Table of Contents

Table of Contents	3
Introduction	4
Scope and Audience.....	4
Safety and Warnings	4
Warranty Registration and Warranty Certificate Request	4
Service	4
Chapter 1. Safety	5
Chapter 2. Overview	9
2.1 Product Description	10
2.2 Product Main Features.....	12
Chapter 3. Hardware Overview	16
3.1 Key Components	17
Chapter 4. Installation	18
4.1 Delivery Space Requirements.....	19
4.2 Site Considerations.....	20
Chapter 5. Operation	29
5.1 Starting the Unit	30
5.2 Turning ON the Unit.....	31
5.3 Communication.....	37
5.4 FRU Replacement	38
Chapter 6. Troubleshooting	39
Appendix A – Options	42
Appendix B - Specifications	58

Introduction

Congratulations on selecting one of the fine products from the leader in power-protection technology. Our wide product offering includes Uninterruptible Power Systems (UPS), power conditioners, automatic voltage regulators, and specialty transformers (e.g., computer-grade, medical-grade). Since 1972, the manufacturer has shipped many of these fine products to discerning customers worldwide for use on sensitive equipment and critical applications.







The Single-Phase Lighting Inverter is a self-contained unit that provides backup power for fluorescent and incandescent lighting sources such as overhead fixtures and exit signs. If a brownout or power outage occurs, the inverter provides 90 minutes of lighting power to ensure a safe building evacuation. OnLine pulse-width modulation (PWM) handles the switchover from utility power to battery power automatically, without interruption or manual intervention. Convection cooling allows the inverter to operate virtually silently.

Scope and Audience

This guide is intended to be used as a reference for users responsible for installing, operating, and maintaining this equipment.

Safety and Warnings

This guide uses the following symbols to draw your attention to certain information.

Symbol	Meaning	Description
	Note	Notes emphasize or supplement important points of the main text.
	Tip	Tips provide helpful information, guidelines, or suggestions for performing tasks more effectively.
	Caution	Cautions indicate that failure to take specified action could result in damage to the hardware.
	DANGER	The Danger symbol warns users of possible injury or death if instructions are not followed.
	Hazardous voltage	Hazardous voltage inside. Only authorized personnel may service this equipment.
	Electrostatic sensitive	Components are Electrostatic Discharge Susceptible (ESDS) Use a grounded ESD wrist strap.

Warranty Registration and Warranty Certificate Request

Web: www.800pwrsrv.com under download tab.

Service

If you require assistance, fill out a Service Report Form at www.800pwrsrv.com, email us at service@800pwrsrv.com, or call our 24-hour toll free hot line (800-797-7782). Please have the unit's SERIAL NO. from the Start-Up **label** located on the top right front door for speed assistance.

Chapter 1. Safety

This chapter contains safety precautions to observe when operating or servicing electrical equipment. The symbols shown are used extensively throughout this manual. Always heed these precautions because they are essential to the safe operation and servicing of this product.



DANGER: This Equipment is intended to be permanently connected. Only factory-trained or authorized personnel should attempt to install or repair the unit or its battery system. Improper installation has proven to be the single most significant cause of start-up problems. High AC and DC electrical voltages are present throughout the unit(s) and incorrect installation, or servicing could result in electrocution, fire, explosion, or equipment failure.



DANGER: Read this manual in its entirety before performing the installation, start-up, operation, or maintenance of the UPS unit or battery systems. Failure to do so could result in electrocution, fire, explosion, or equipment failure.



DANGER: All power connections must be completed by a licensed electrician who is experienced in wiring this type of equipment. Wiring must be installed in accordance with all applicable national and local electrical codes. Improper wiring may cause damage to the equipment, injury, or death of personnel. Verify that all high and low-voltage input power circuits are de-energized and locked out before installing cables or making any electrical connections.



DANGER: Exercise extreme care when handling the unit and batteries to avoid equipment damage or injury to personnel. Cabinets weigh several hundred pounds.



DANGER: Test lift and balance the cabinets before moving. Maintain minimum tilt from vertical at all times. The bottom structure will support the unit only if the forklift forks are completely underneath the unit.



DANGER: Observe all battery safety precautions during the installation or service of the unit or batteries. Even with the battery circuit breaker in the off position, the danger of electrocution may still be present. The battery power to the unit must be locked and tagged "off" before performing any service or work on the unit. The battery manufacturer's safety information and material safety data sheet are located in a pocket attached to the front door of each unit. Failure to follow those instructions and the instruction listed above and elsewhere in this manual could result in an explosion, fire, equipment failure, or electrocution.



DANGER: All power to the unit must be locked and tagged "off" before performing any service or work on the unit. Failure to do so could result in electrocution.



DANGER: In case of fire involving electrical equipment, only carbon dioxide fire extinguishers, or those approved for use on electrical equipment, should be used. The use of water on fires involving live high-voltage electrical circuits could present an electrocution hazard.



DANGER: Extreme caution is required when performing maintenance. Lethal voltages exist within the equipment during operation. Observe all warnings and cautions in this manual. Failure to comply may result in serious injury or death. Obtain qualified service for this equipment as instructed.



DANGER: Be constantly aware that the unit system contains high DC as well as AC voltages. With input power off and the battery disconnected, high voltage at the filter capacitors and power circuits should discharge within 30 seconds. However, power circuit failures can occur, so you should always assume that high voltage might still exist after shutdown. Verify that power is off using AC and DC voltmeters before making contact.



DANGER: Some components within the cabinets are not connected to the chassis ground. Any contact between floating circuits and the chassis is a lethal shock hazard.



DANGER: Internal battery strapping must be verified by the customer prior to moving this unit.

This unit contains non-spillable batteries. Keep the unit upright. Do not stack. Do not tip. Always follow the battery manufacturer's safety information, located in a pocket attached to the inside of the door of your unit, to prevent an accident that could result in injury or death.



DANGER: Lead-acid batteries contain hazardous materials. Batteries must be handled, transported, and recycled or discarded following federal, state, and local regulations. Because lead is a toxic substance, lead-acid batteries should be recycled rather than discarded.

Do not dispose of batteries in a fire, as the batteries may explode.

Do not open or mutilate the batteries. Released electrolytes are harmful to the skin and eyes and may be toxic.

A battery can have a high short circuit current and present a risk of electrical shock. The following precautions should be observed when working on batteries:

- 1. Remove watches, rings, or other metal objects.**
- 2. Use tools with insulated handles.**
- 3. Wear rubber gloves and boots.**
- 4. Do not lay tools or metal parts on top of batteries.**
- 5. Disconnect the charging source prior to connecting or disconnecting battery terminals.**
- 6. Determine whether the battery is inadvertently grounded. If so, remove the source of the ground. Contact with any part of a grounded battery can result in electrical shock. The likelihood of such shock will be reduced if such grounds are removed during installation and maintenance.**
- 7. Lead-acid batteries can present a risk of fire because they generate hydrogen gas. The following procedures should be followed:**
 - Do not smoke when near batteries.
 - Do not cause flame or spark in the battery area.
- 8. Discharge static electricity from your body before touching batteries by first touching a grounded surface.**

Chapter 2. Overview

Topics:

- ^ *2.1 Product Description*
(page 10)
- ^ *Table 2-2. Model Numbers*
(page 11)
- ^ *2.2 Product Main Features* (page 12)

This chapter provides an overview of the Single-Phase Lighting Inverter

2.1 Product Description

The Single-Phase Lighting Inverter is manufactured to provide critical power for lighting during a power outage. The Lighting Inverter meets or exceeds the life safety codes of UL924 and UL1778. These codes were established to allow emergency lighting inverters to provide critical power to the lighting circuits during a power failure.

If input power to the inverter is lost during a power outage, the system draws clean sine wave power automatically from its internal battery supply without any interruption. Power is provided for 90 minutes, sufficient time for safe and orderly evacuation from the facility.

An optional Input or output or both transformer(s) allows a 277V input or output voltage unit. The internal valve-regulated lead-acid (VRLA) maintenance-free batteries provide 90 minutes of backup power. When input power is restored, the Lighting Inverter resumes normal operation automatically and begins recharging the batteries immediately.

An optional internal bypass circuit maintains power to the load in case an internal unit failure occurs. Comprehensive monitoring capabilities include a Liquid Crystal Display (LCD) panel and five dry relay contacts for remote monitoring.

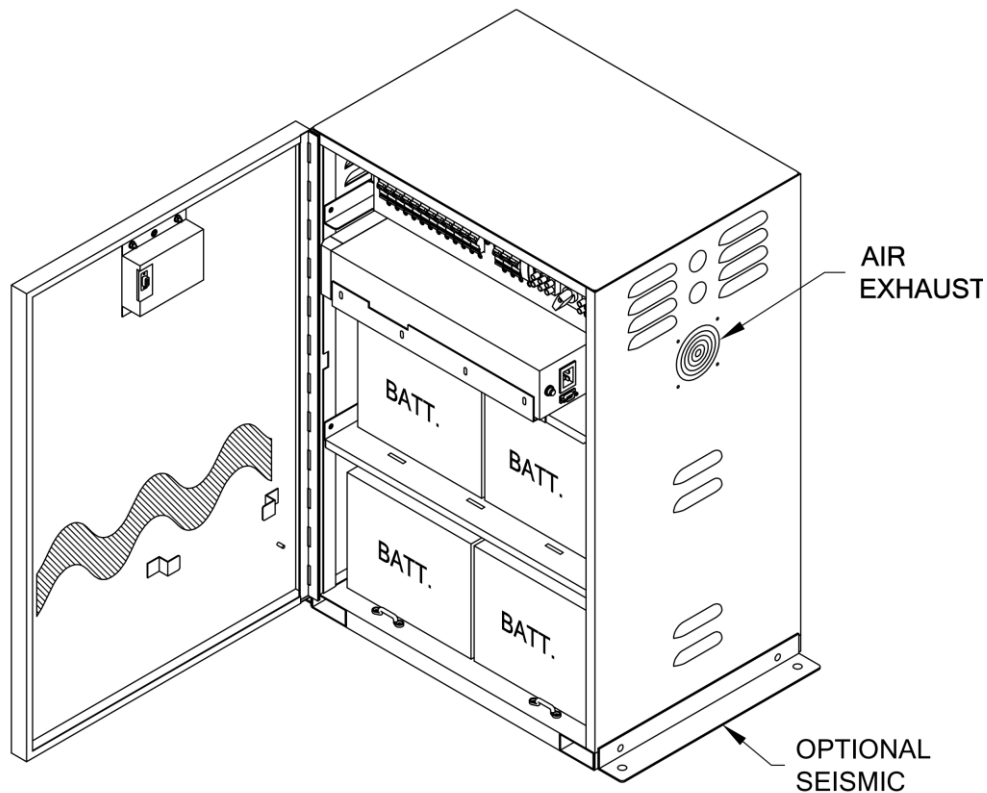

Table 2-1. Mini Power Wave Cabinet

Table 2-2. Model Numbers

Watts	Model Numbers	Input/Output	BTU/HR*	Weight Inverter & Battery
500	MW.50A0100N1	120/120	478	275 LBs
	MW.50R0100T1	277/120	550	"
	MW.50A2500T1	120/277	550	"
	MW.50R2500T1	277/277	550	"
750	MW.75A0100N1	120/120	492	370 LBs
	MW.75R0100T1	277/120	575	"
	MW.75A2500T1	120/277	575	"
	MW.75R2500T1	277/277	575	"
1000	MW1.0A0100N1	120/120	615	370 LBs
	MW1.0R0100T1	277/120	675	"
	MW1.0A2500T1	120/277	675	"
	MW1.0R2500T1	277/277	675	"
1250	MW1.2A0100N1	120/120	780	460 LBs
	MW1.2R0100T1	277/120	890	"
	MW1.2A2500T1	120/277	890	"
	MW1.2R2500T1	277/277	890	"
1500	MW1.5A0100N1	120/120	925	510 LBs
	MW1.5R0100T1	277/120	1100	"
	MW1.5A2500T1	120/277	1100	"
	MW1.5R2500T1	277/277	1100	"
2100	MW2.1A0100N1	120/120	1175	570 LBs
	MW2.1R0100T1	277/120	1525	"
	MW2.1A2500T1	120/277	1525	"
	MW2.1R2500T1	277/277	1525	"
2500	MW2.5A0100N1	120/120	1351	720 LBs
	MW2.5R0100T1	277/120	1813	"
	MW2.5A2500T1	120/277	1813	"
	MW2.5R2500T1	277/277	1813	"
2700	MW2.7A0100N1	120/120	1392	730 LBs
	MW2.7R0100T1	277/120	2103	"
	MW2.7A2500T1	120/277	2103	"
	MW2.7R2500T1	277/277	2103	"

2.2 Product Main Features

The Single-Phase double conversion on-line Emergency Lighting Inverter uninterruptable, clean, Single-Phase power to your critical systems while keeping batteries continuously charged and providing a back-up in the event of a utility power failure.

If a power failure lasts longer than the rated UPS backup time, your UPS will shut down systematically, avoiding battery discharge. As soon as utility power is restored, the UPS will automatically switch to utility power and start recharging the batteries.

As shown in the Single Line diagram, Figure 2-1

- An input filter reduces transients on the mains.
- To maintain a full battery charge, AC power is rectified and regulated in the rectifier feeding power to the inverter and battery charger.
- DC power is converted to AC in the inverter passing it on to the load.
- Power is maintained from the battery during power failure. The converter increases the voltage to the inverter.

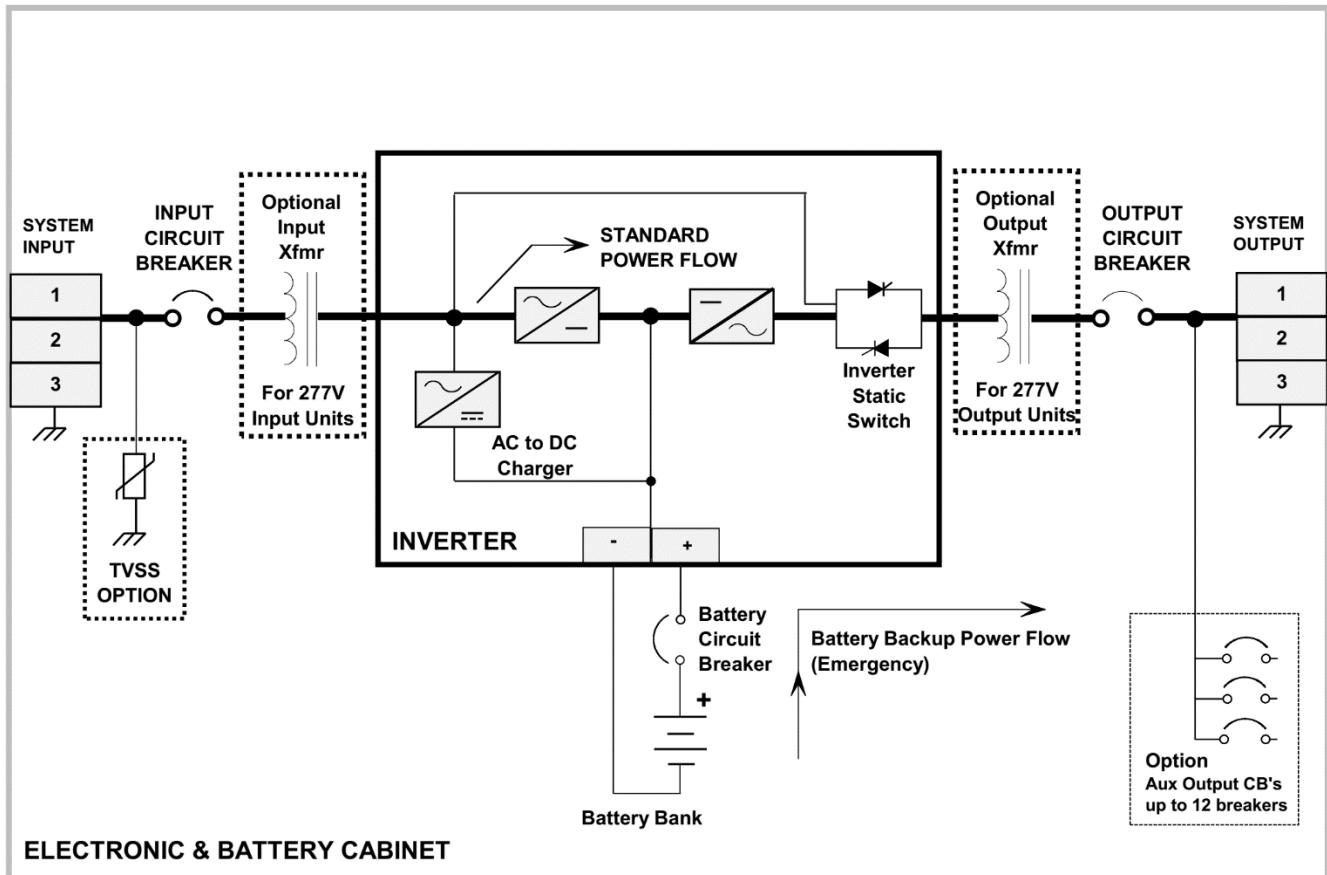

Figure 2-1. Mini Power Wave Single Line Diagram (typical)

2.2.1 Efficiency Optimizer Function

The Efficiency Optimizer Function is a new feature of your UPS that adds cost-effectiveness, provides minimal power loss, and reduced power consumption. Alternating between bypass and on-line modes is achieved automatically and in accordance with the conditions of the utility power to obtain the greatest efficiency, on-line mode may function during times of intermittent utility power availability and bypass mode when power flows smoothly. Irregularities can be detected in less than a second, and on-line mode is reactivated immediately. Switching back to online mode occurs when the input voltage exceeds $\pm 10\%$ of nominal ($\pm 15\%$ selectable) when the input frequency exceeds $\pm 3\text{Hz}$ of nominal or when no input line voltage is detected.

An available option allows default operation in the on-line mode. Bypass can be activated from the LCD panel, though on-line mode can be run permanently if preferred.

2.2.2 Normal Operation:

There are two main loops when the AC utility is Normal.

- **The AC loop**

The AC output power comes from the AC utility input and passes through the AC/DC rectifier, DC/AC inverter, and static switch to support power to the load.

- **Battery charging loop**

The battery charging voltage comes from the AC utility input and is converted by the AC/DC charger to support battery charging power.

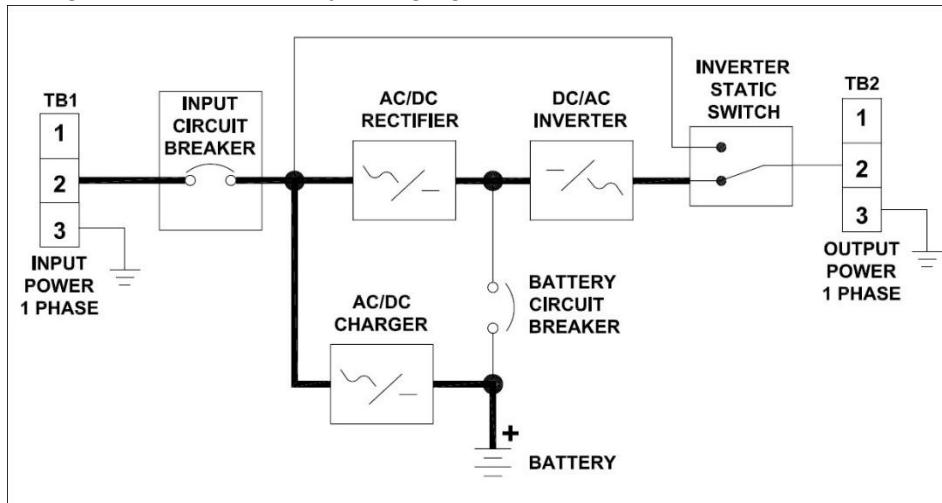

2.2.3 AC Utility failure:

The AC output power comes from the battery and passes through the DC/AC Inverter, and the Static Switch to provide power to the load.

The battery charging path is from the AC utility input to the AC/DC Charger to charge the battery.

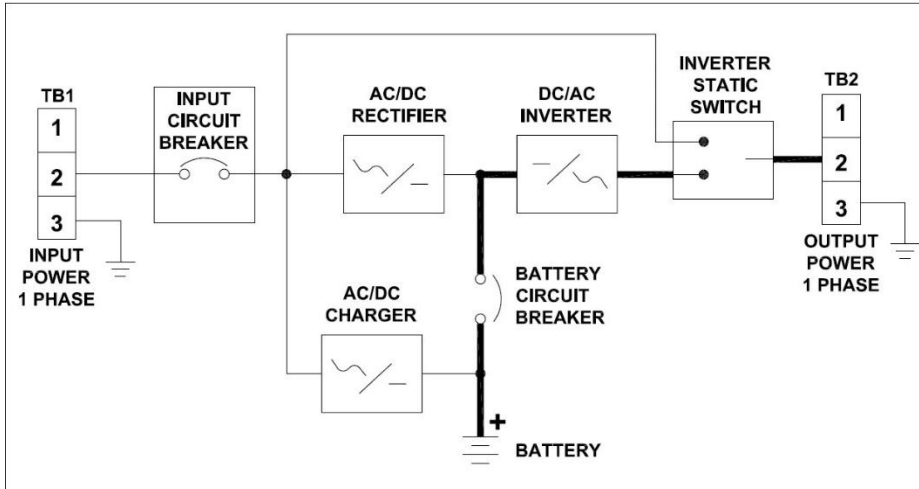

2.2.4 Bypass Enable:

Under the Following Conditions, the bypass will be enabled:

1. Overload
2. Inverter failure
3. Over temperature
4. DC bus failure

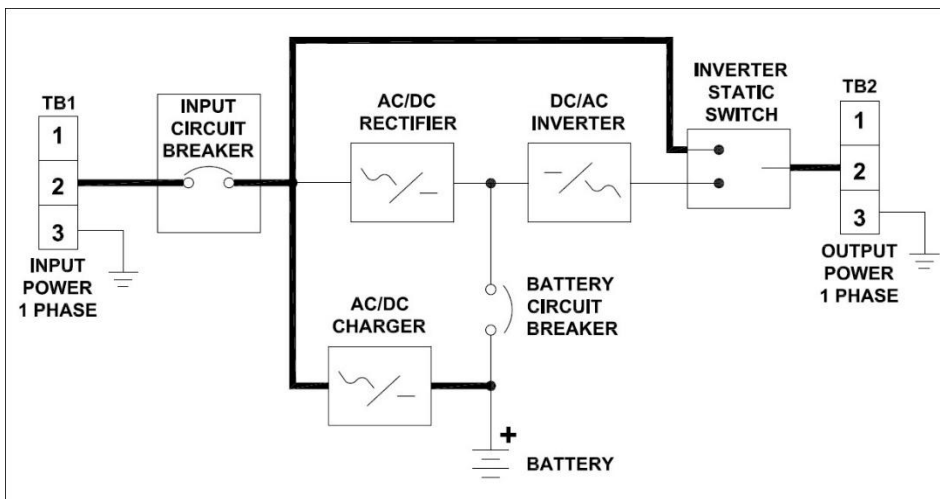

2.2.5 Free Run Mode

The UPS operates in free-run mode when the input frequency is outside of the selected input frequency range. In free-run mode, the output frequency does not match the input frequency. When starting the UPS, the frequency regulation detected is 50 or 60 Hz ± 0.25 Hz

2.2.6 Diagnostic tests

When you start the UPS, a diagnostic test is automatically executed that checks the electronics and battery and reports any faults on the LCD screen.

An advanced battery management system always monitors the conditions of the batteries, sends a warning if replacement is needed, or every 30 days of normal mode operation, a battery discharge test is automatically performed, and any faults are reported on the LCD screen.

Diagnostic tests can be performed manually from the front panel at any time except during the first 24 hours after startup while the UPS is in charging mode.

Chapter 3. Hardware Overview

Topics:

- ^ *Key Components description (page 17)*

This chapter provides an overview of the system's key components.

3.1 Key Components

Figure 3-1 shows the key system components and describes them.

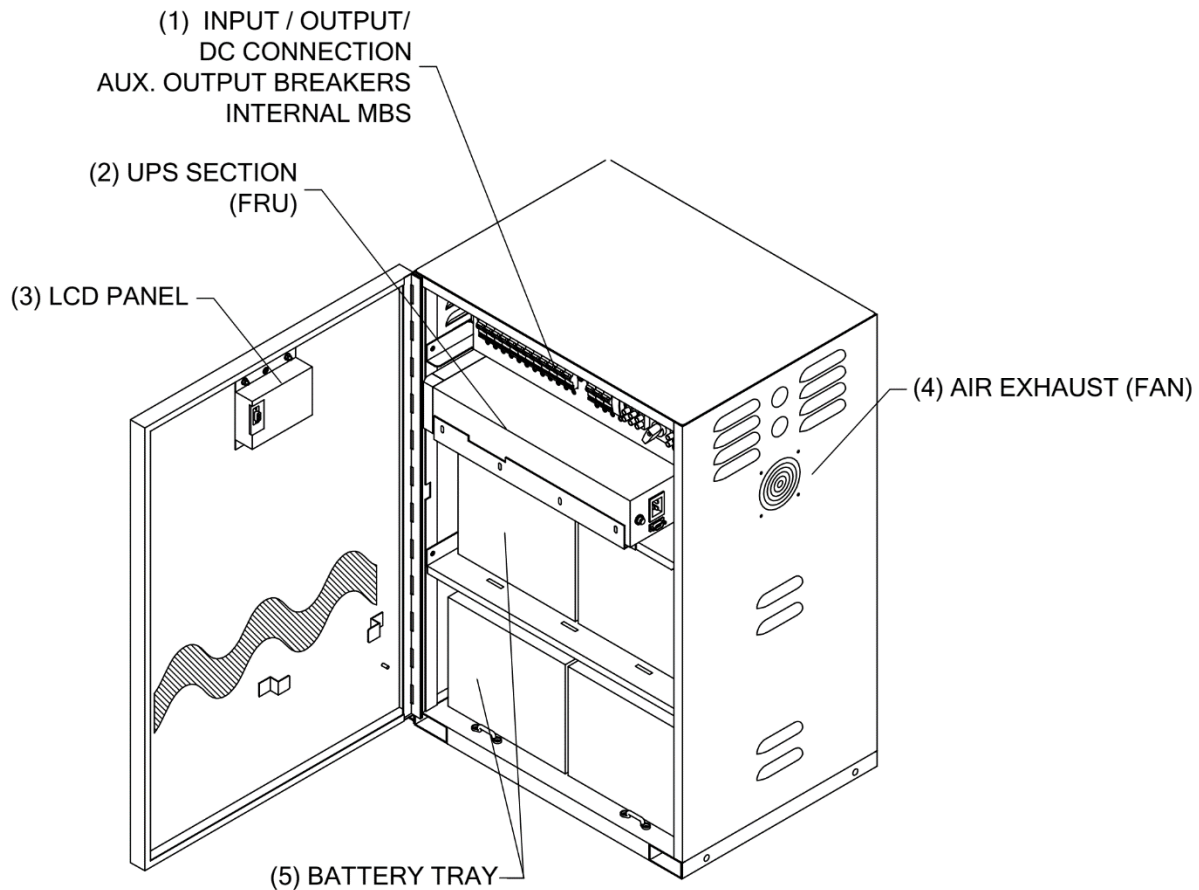

Figure 3-1. Mini Power Wave Key Components

Table 3-1. Key Components description

Callout	Components	Function
1	INPUT / OUTPUT / DC CONNECTION	Conveniently located close to knockout terminal blocks for Input, Output, and Battery connection.
	OPTIONAL AUX. OUTPUT BREAKERS	Auxiliary Norm ON C.B options, 1pole, 20amp (maximum of 12 each).
	INTERNAL MAINTENANCE BYPASS SWITCH MBS	MBS (Maintenance By-pass Switch – manual).
2	UPS section	The UPS section of the unit is a module unit and is offered as a Field replacement unit (FRU).
3	LCD Panel	Refer to Chapter 5 for details.
4	Fan and Fan grill	This fan works as exhaust air and should not be abstracted by objects for free airflow.
5	Batteries	Each system includes 2 battery trays which hold 4 Batteries each, for a 96VDC power.

Chapter 4. Installation

Topics:

^

^ *4.1 Delivery Space Requirements*
(Page 19)

^

^ *4.2 Site Considerations (page 20)*

This chapter describes how to install the system. It includes pre-installation information along with guidelines for storing the system for future use.

4.1 Delivery Space Requirements

The following figures show the dimensions of the system cabinets as well as key components used for cable access and mounting.

Verify that the delivery area, the destination, and the path between them meet the standard delivery clearance and weight requirements of the system.

The delivery area must provide enough space and floor strength to support the packaged equipment cartons for the system. Doorways and hallways must provide enough clearance to move the equipment safely from the delivery area to the destination. Permanent obstructions such as pillars or narrow doorways can cause equipment damage. If necessary, plan for the removal of walls or doors.

Verify that all floors, stairs, and elevators you use when moving the system to its destination can support the weight and size of the equipment. Failure to do so could damage the equipment or your site.

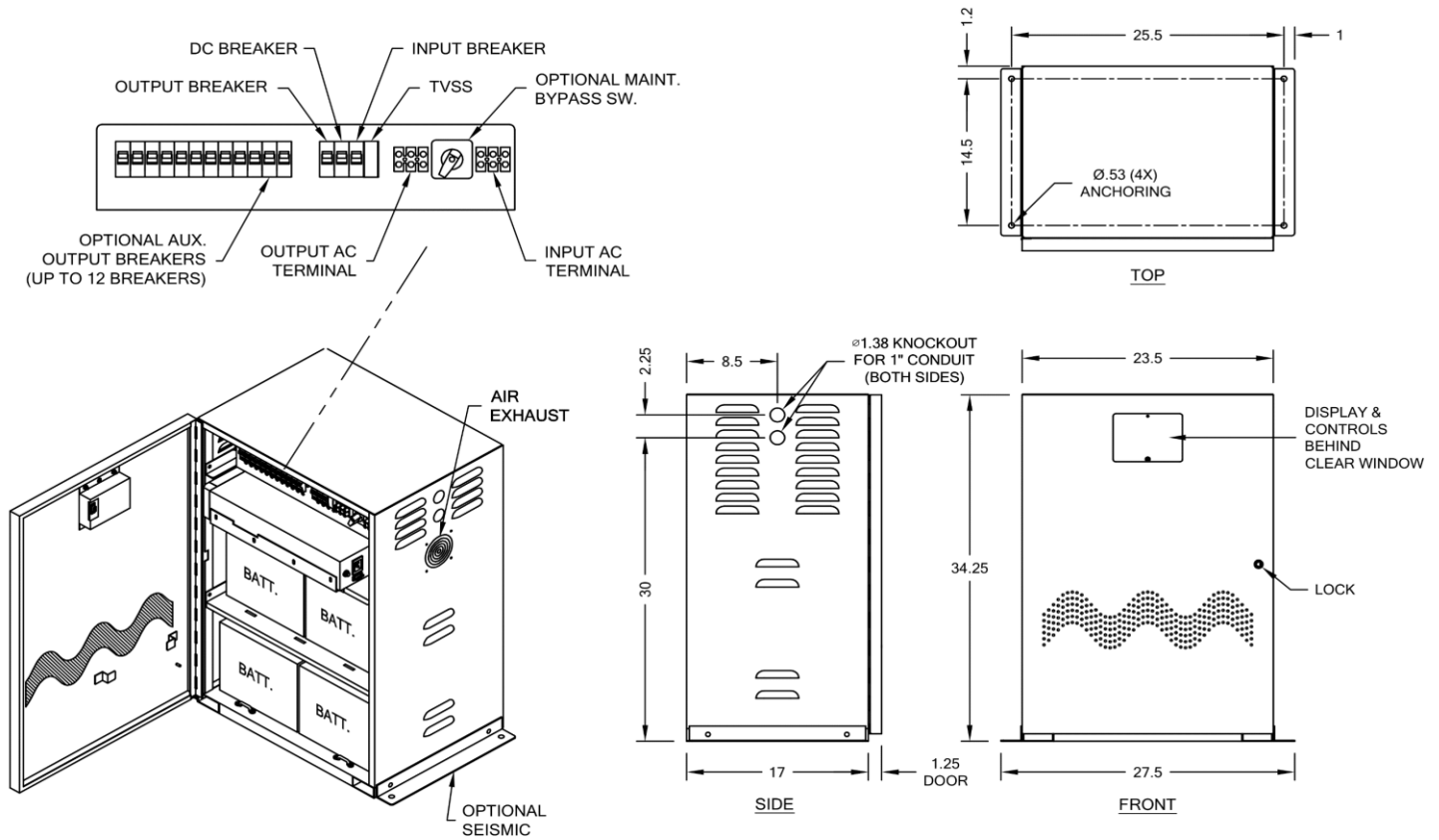

Figure 4-1. Cabinet Access and Mounting



Note: Do not remove any knockouts that will not be used

4.2 Site Considerations

Planning the proper location and layout of the system prior to installing it is essential for successful operation. To ensure normal operation and to avoid unnecessary maintenance, plan your site configuration and prepare your site before installation.

The system is designed for indoor installation and meets NEMA specifications for operating temperature, humidity, and utility voltage. The system enclosures are rugged and corrosion resistant.

All servicing is performed through the front of the unit; therefore, leave sufficient room in the front of the unit for service access.

The following precautions will help you plan an acceptable operating environment for the system:

- **Select a flat location that is clean, with no dust or exposure to direct sunlight or vibrations. The location should provide a sturdy, level surface that can support the system. Avoid locations with inclined floors.**
- **The location should not be prone to variations in temperature and humidity or be close to strong magnetic fields or a device that generates electric noise.**
- **The unit should not place the system next to, on top of or below any device that generates heat or will block the free flow of air through the system's ventilation slots.**
- **The Lighting Inverter cabinets provide cable and conduit openings on the top and sides of the cabinet. Be sure these areas are not blocked and can be easily accessed to expedite installation.**
- **Electrical equipment generates heat. Ambient air temperature might not be adequate to cool equipment to acceptable operating temperatures without adequate circulation. Ensure that the room in which the system will operate has adequate air circulation.**



Caution: Always follow proper ESD-prevention procedures to avoid damage to equipment. Damage from static discharge can cause immediate or intermittent equipment failure.



Caution: For sites with a **Generator** and **Automatic Transfer Switch (ATS)** in conjunction with the unit, make sure the ATS has an open transition with a minimum 20 milli-second transfer time (gap) in **both directions**

4.2.1 Recommended Facility Protective Device Ratings, BTU/HR, Floor Loading

Table 4-1

UPS Rating (Watts/KW)	Input Volt.	Unit Input Circuit Breaker (Amps)	Recommended Facility Input Circuit Breaker Over Current Protection (AMP)	Output Volt.	Unit Output Circuit Breaker (Amps)	Recommended Facility Output Circuit Breaker Over Current Protection (AMP)	Batt. Volt	Max. Batt. Disch. AMP	Full Load BTU/HR Max	Unit Weight (including Batteries) lbs	Floor Loading LB/SQFT	Cabinet Dimensions W x D x H Inches
500W	120	20	Recommended Facility Input Circuit Breaker Should Be Equal to or Larger Than the Unit Input Circuit Breaker Ampacity	120	6	Recommended Facility Output Circuit Breaker Should Not Be Larger Than the Unit Output Circuit Breaker Ampacity	96	8.22	478	275	61	24 x 34 x 18
	120	20		277	6		96	8.22	550	275	61	24 x 34 x 18
	277	10		120	6		96	8.22	550	275	61	24 x 34 x 18
	277	10		277	6		96	8.22	550	275	61	24 x 34 x 18
750W	120	20		120	10		96	11.43	492	370	82	24 x 34 x 18
	120	20		277	6		96	11.43	575	370	82	24 x 34 x 18
	277	10		120	10		96	11.43	575	370	82	24 x 34 x 18
	277	10		277	6		96	11.43	575	370	82	24 x 34 x 18
1 KW	120	20		120	10		96	15.15	615	370	82	24 x 34 x 18
	120	20		277	6		96	15.15	675	370	82	24 x 34 x 18
	277	10		120	10		96	15.15	675	370	82	24 x 34 x 18
	277	10		277	6		96	15.15	675	370	82	24 x 34 x 18
1.25 KW	120	20		120	20		96	18.94	780	460	101	24 x 34 x 18
	120	20		277	6		96	18.94	890	460	101	24 x 34 x 18
	277	20		120	20		96	18.94	890	460	101	24 x 34 x 18
	277	20		277	6		96	18.94	890	460	101	24 x 34 x 18
1.5 KW	120	32		120	20		96	22.73	925	510	113	24 x 34 x 18
	120	32		277	6		96	22.73	1100	510	113	24 x 34 x 18
	277	20		120	20		96	22.73	1100	510	113	24 x 34 x 18
	277	20		277	6		96	22.73	1100	510	113	24 x 34 x 18
2.1 KW	120	32		120	20		96	31.81	1175	570	126	24 x 34 x 18
	120	32		277	10		96	31.81	1525	570	126	24 x 34 x 18
	277	20		120	20		96	31.81	1525	570	126	24 x 34 x 18
	277	20		277	10		96	31.81	1525	570	126	24 x 34 x 18
2.5 KW	120	40		120	25		96	32.74	1351	720	159	24 x 34 x 18
	120	40		277	20		96	32.74	1813	720	159	24 x 34 x 18
	277	20		120	25		96	32.74	1813	720	159	24 x 34 x 18
	277	20		277	20		96	32.74	1813	720	159	24 x 34 x 18
2.7 KW	120	40	120	25	96	35.36	1392	730	161	24 x 34 x 18		
	120	40	277	20	96	35.36	2103	730	161	24 x 34 x 18		
	277	20	120	25	96	35.36	2103	730	161	24 x 34 x 18		
	277	20	277	20	96	35.36	2103	730	161	24 x 34 x 18		



For all wire sizes consult local codes and NEC based on unit current requirements.

Input / Output power connections (terminal blocks), accepting 14 AWG to 2/O AWG.

The external input circuit breaker protecting the unit must be a delayed trip type. This is due to magnetic inrush current drawn during application of AC power.

4.2.2 Operating Environment

The location you choose for installation should conform to the following conditions.

Table 4-2. Inverter Environmental Specifications

Inverter Environment	Description
Operating Temperature:	0° to 40°C (32 to 104°F) Battery compartment to be kept at battery operating temperature
Altitude:	1,829 meters (6,000 feet) de-rate 10% for each additional 305 meters (1,000 feet) up to 2,744 meters (9,000 feet)
Relative humidity:	0% to 95% (non-condensing)
Audible Noise:	57 dBA, typical

Table 4-3. Battery Environmental Specifications

Battery Environment	Description
Ambient temperature:	20° to 25°C (68° to 77 °F)
Relative humidity:	0% to 95% (non-condensing)
Operating altitude:	1,829 meters (6,000 feet) de-rate 10% for each additional 305 meters (1,000 feet) up to 2,744 meters (9,000 feet)



Caution: Operating batteries outside of the specifications will shorten battery life significantly.

4.2.3 Floor Load Ratings

The floor space at the installation site must be strong enough to support the combined weight of the Lighting Inverter unit and all its batteries. To ensure adequate load-bearing capacity, plan for the maximum configuration.

4.2.4 Inspecting the Shipment

The equipment included in your shipment consists of one Lighting Inverter cabinet. Batteries will typically ship separately unless specified otherwise. The contents are covered with protective wrapping and packaged in heavy-duty cardboard. Each item is labeled with a component name for easy identification.

When the equipment arrives, count the number of items delivered to ensure that you have the complete shipment. Inspect all protective wrapping or crates and any boxes for signs of rough handling or damage, such as punctures and crushed sides, preferably without moving the equipment. If the shipping container or equipment itself shows evidence of damage, record the damage on the receiving document before signing for receipt of the equipment. Damage claims should be filed directly with the carrier.

Thoroughly inspect each battery for any signs of damage. If there is any damage, reject the shipment and notify the manufacturer by email at service@800pwrsrvc.com. If possible, photograph the damage for future reference. As you unpack the pallet or container, check each battery box for damage on all sides, the top and bottom. If there is any sign of damage, photograph the damage if possible, and email service@800pwrsrvc.com.

4.2.5 Offloading the System

Because the system is designed for pad mounting, it is not accompanied by casters. At the user's discretion, a forklift can be used to offload the unit from the shipping pallet. Always be sure that the load capacity of the forklift is sufficient to support the weight of the unit and its batteries.



DANGER: Exercise extreme care when handling the cabinets to avoid equipment damage or injury to personnel. Each cabinet weighs several hundred pounds. Test lift and balance the cabinets before moving. Always maintain minimum tilt from vertical. The bottom structure will support the unit only if the forklift forks are completely underneath the unit.

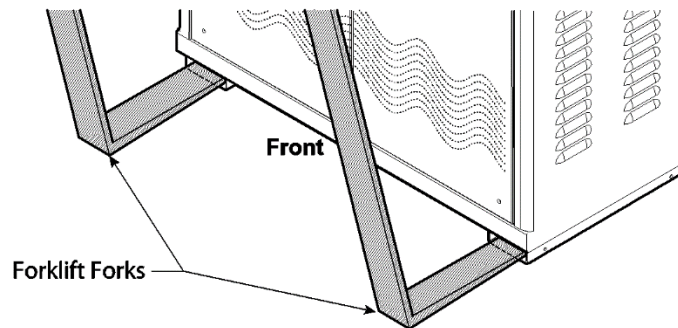

4.2.6 Climatization

Units that are shipped or stored at extreme temperatures require time to adjust to operating temperatures before startup. If the unit arrives in hot or cold weather, do not unpack it until it has been allowed to reach room temperature (one to two hours). Immediately exposing the unit to warm temperatures can cause condensation to occur, which could damage the electronics. If you notice any condensation, allow the unit to stand unattended for one to two hours, and then unpack it.

4.2.7 Unpacking the Equipment

After checking the cartons for signs of damage, perform the following steps to unpack the equipment:

1. **Open all cartons.**
2. **Compare the items received to the packing list. If an item is missing or damaged, contact the place of purchase.**
3. **Remove all packing materials, envelopes, and boxes from the cartons. Please keep all packing materials and cartons in case you need to transport or ship the unit.**

In addition to the contents supplied with the unit, the user must supply a forklift to perform the installation.



Note: After unpacking and **before turning on:**

use the plastic cover provided in the pouch on the front door to cover the unit during installation and while waiting for turn on, to prevent dust, construction debris, and any other foreign object from entering the unit.

Accumulation of dust and debris on any of the electronics will cause damage which will not be covered by the warranty.

4.2.8 Cabling and Mounting

The top and sides of the unit have conduit openings for running cables.

1. **Before placing the unit onto the mounting bolts where it will be installed, remove the predrilled conduit knockouts on the top and sides of the cabinet.**



Note: The predrilled conduit knockouts are positioned to prevent airflow disruptions that could cause the unit to overheat. If site restrictions prevent routing the conduit to the locations of the conduit knockouts, do not drill holes in the cabinet without first consulting the factory via email at Service@800pwrsrc.com. Our engineers will assist you in locating the conduit to maintain unit reliability.

2. **Determine which knockouts will be used to route cables into and out of the unit. Remove only the conduit knockouts that are to be used.**
3. **Measure the locations for the conduits on the conduit knockouts.**
4. **Punch holes in the conduit knockouts.**
5. **Anchor the cabinet to the mounting pad at the four mounting locations.**
6. **Anchor the conduits to the conduit knockouts.**



Note: Do not remove any knockouts that will not be used

4.2.9 Electrical Connections

The following sections describe how to perform the electrical connections. In these sections, “TB” refers to a terminal block. Before making electrical connections, observe the following:



DANGER: Verify that all customer-supplied wiring is de-energized before performing any electrical work. Failure to do so could result in electrocution, injury, or damage to equipment.



DANGER: Even when the unit is off, there are potentially dangerous voltages within the power wave unit due to the batteries. Exercise extreme care when working within the power wave enclosure to avoid the possibility of electrocution, injury, or damage to the equipment.

4.2.9 Input/Output/Load Connection

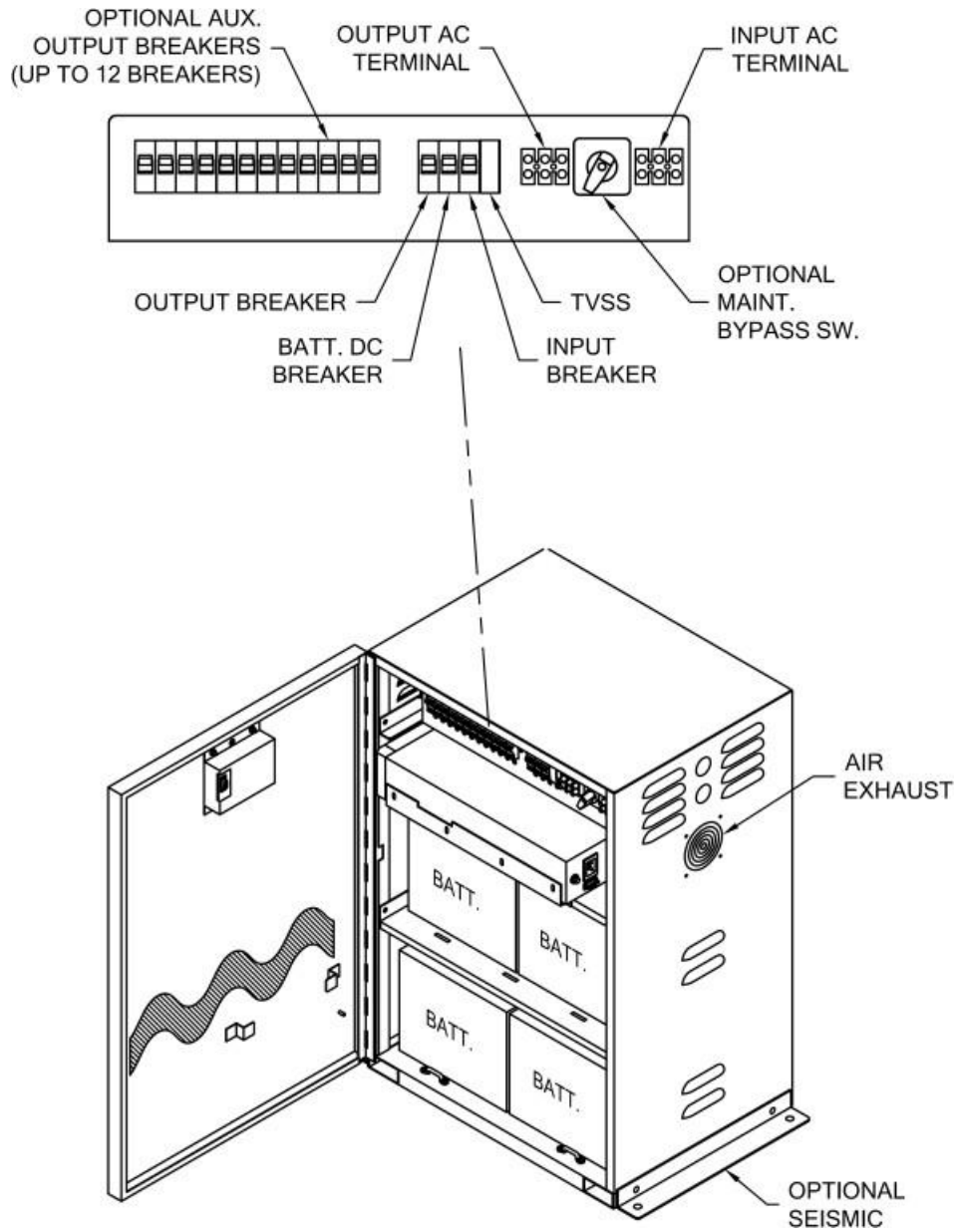

Figure 4-2. Power connection

SYSTEM RATING (WATTS)	INPUT / OUTPUT/ DC TB
500W – 2700W	#22 - #6 AWG

Table 4-4. Battery Torque Values

SYSTEM RATING (WATTS)	(BATTERY TYPE) TORQUE (INCH LBS)	(BATTERY TYPE) TORQUE (INCH LBS)
500W	UB12260 (59 IN-LBS)	HPS12-90W-XFR (55 IN-LBS)
750W	UB12350 (59 IN-LBS)	HPS12-90W-XFR (55 IN-LBS)
1000W	UB12350 (59 IN-LBS)	UNA12-115 (55 IN-LBS)
1250W	UB12500 (59 IN-LBS)	UNA12-150 W (75 IN-LBS)
1500W	UB12550 (59 IN-LBS)	HF12-211W-XFR (75 IN-LBS)
2100W	UB12750 (59 IN-LBS)	UNA12-200 (75 IN-LBS)
2500W	HRL12280WFR (45 IN-LBS)	UNA12-320 (75 IN-LBS)
2700W	HRL12280WFR (45 IN-LBS)	UNA12-320 (75 IN-LBS)

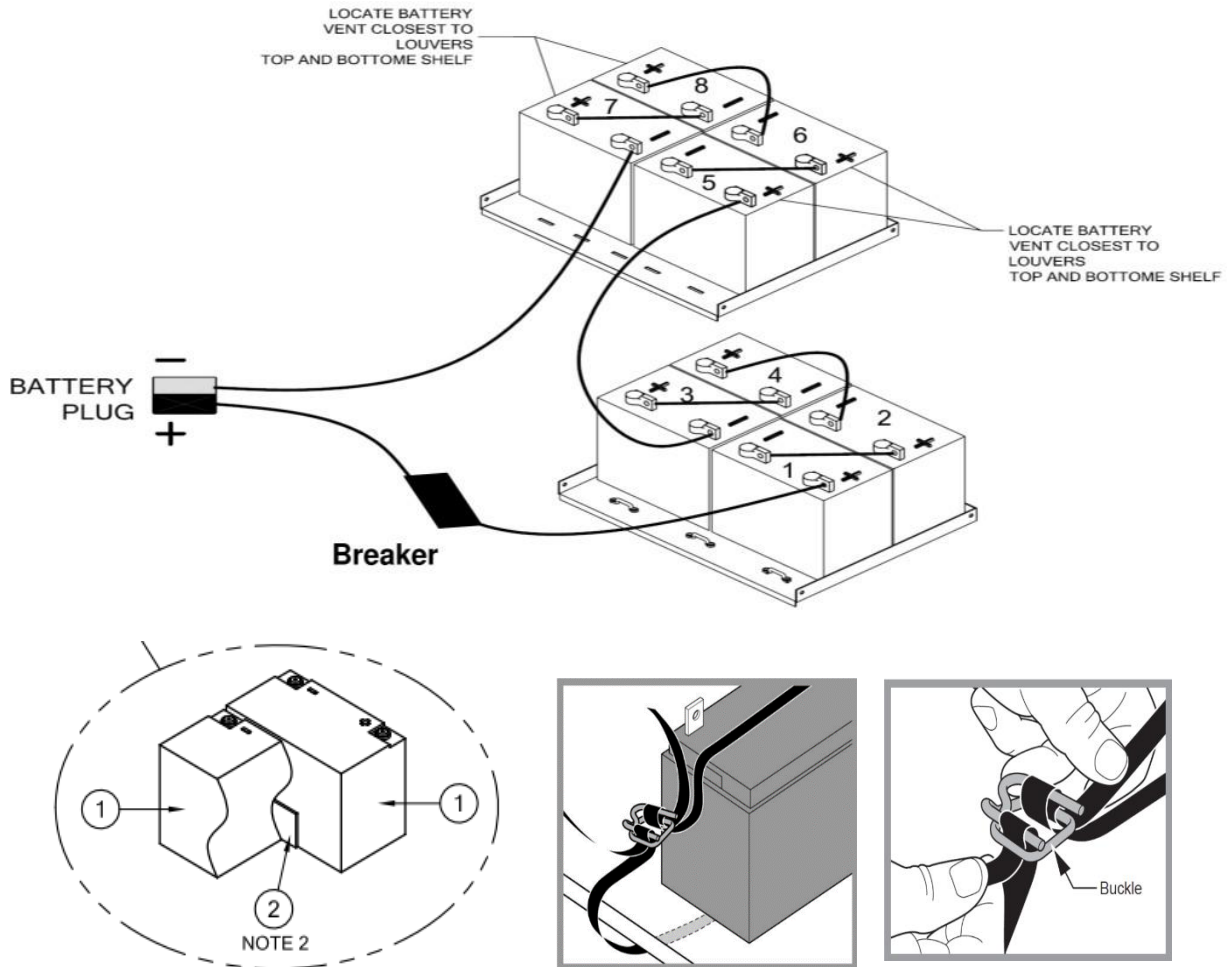

Figure 4-3. Battery Installation, Connection, and Buckling

The Installation is now complete.

4.2.10 Storing the System

If you will not be using the system as soon as you receive it, keep it in its original packing material and store it in an indoor environment that meets the following conditions.

Specification	Description
Ambient temperature:	-20° to 70°C (-4° to 158°F)
Relative humidity:	0% to 95% (non-condensing)



Note: After unpacking and **before turn-on:**

Use the plastic cover provided in the pouch on the front door to cover the unit during installation and while waiting to turn on, to prevent dust, construction debris, and any other foreign object from entering the unit.

Accumulation of dust and debris on all electronics will cause damage which will not be covered by warranty.

4.2.11 Recharging Batteries During Storage

If the unit will be stored for three months or longer, visually inspect, and charge the batteries for 24 hours at regular, three-month intervals, refer to the battery label for battery voltage and use the appropriate charger.

Chapter 5. Operation

Topics:

^

^

^ *5.1 Starting the Unit (page 29)*

^ *5.2 Turning ON the Unit (page 30)*

^ *5.3 Communication (page 36)*

^ *5.4 FRU Replacement (page 37)*

This chapter describes how to operate the unit.

5.1 Starting the Unit

Please be sure not to start up the unit without the assistance of factory-trained authorized personnel, as failure to do so may damage the unit and void the unit warranty.

To request a start-up: Either complete the form (6002-1545) online and email it to service@800pwrsvrvc.com or fax a printed copy to Power Services at (323) 721-3929.



Caution: Ensure the unit is clean and free of dust and debris.

2.2.7 Preparation of Batteries

1. Ensure the proper number of batteries are delivered with your order. Verify quantity against battery drawing inside the door.
2. Place battery ID (Number) labels on each battery, refer to Battery Installation and Connection Instruction
3. Ensure batteries are charged within 3 months, after the initial receipt, follow the Service Log sheet (6002-2017-04) for the battery maintenance schedule to protect the warranty.
4. Ensure that battery cables are properly torqued to the battery terminals. See battery drawing for torque values, found within the unit's door panel.
5. Verify that the batteries are in a temperature-controlled environment.

2.2.8 Preparation of Electronics



Caution: Ensure there is proper ventilation and temperature control to ensure **NO MOISTURE** is introduced to the electronics which will void the warranty.

1. Ensure the facility load is within the full load rating of the electronics. The full load power rating of the unit can be found on the nameplate within the inner cabinet door.
2. Make sure all input power, output power, and DC terminal blocks are properly torqued.



Caution: All loads must be verified for a short circuit test before connecting to the output of the unit.



Note: The pre-start-up procedure described in this manual is a reference only to a start-up of the UPS for maintenance and shutdown.

5.2 Turning ON the Unit

Follow the instructions below for the UPS operation.

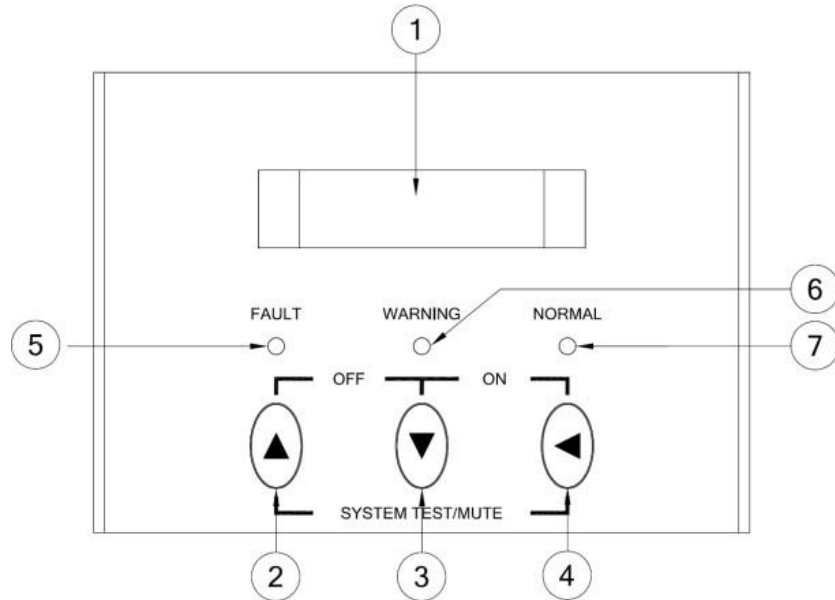

Figure 5-1 LCD Display

No	Switch	Function
4	ON-OFF CONTROL KEY	When this key is pressed with the LCD Select Down-Key simultaneously for 3 seconds, the UPS will switch on if the unit is not in the battery backup mode. Press both the ON-OFF Control key and LCD Select UP key at the same time to disable the beeps.
2	SELECT UP-KEYS	Press up to select the UPS status on the LCD Display. Press the LCD Select Down-key simultaneously for 3 seconds to turn off the UPS.
3	SELECT DOWN-KEY	Press down to display the UPS Status.
1	LCD DISPLAY	This LCD Display shows UPS operation information, including UPS status, input/output voltage, input/output frequency, battery voltage, battery capacity remaining, output load, inside temperature, and the historical event log with the time of each event. Additionally, the UPS output voltage and output frequency can be set from the LCD panel.
5	FAULT LED	The red LED indicates that the UPS is in a fault condition because of inverter abnormality, over-temperature, or DC BUS fault.
6	WARNING LED	The yellow LED indicates that the UPS is overloaded, in bypass or battery backup mode.
7	NORMAL LED	The green LED illuminates when the UPS is operating normally.

Table 5-1. Main Components on LCD Display

5.2.1 Operation/Turn-on Procedure

Follow the instructions below for system operation.

5.2.1.1 Starting and shutting down the unit

Ensure that the unit is correctly installed in accordance with all building and safety codes and that the input power cable and ground are secured.

1. Switch the external input breaker to "ON" and check the voltage at the "input AC terminal"
2. Switch the internal UPS input breaker to "ON"
3. Turn the battery breaker to "ON"
4. Press power buttons  located on the front display
5. Switch the output Breaker(s) to "ON"



Note: During this inspection, the LCD will display "Ready on". The LED will light up when the output power is available, and the LCD will display "Line mode."

6. Turn on the loads.

5.2.1.2 Shutting down the UPS

1. Switch the Output breaker(s) to "OFF"
2. Switch the Battery Breaker to "OFF"
3. Switch the Input breaker to "OFF"

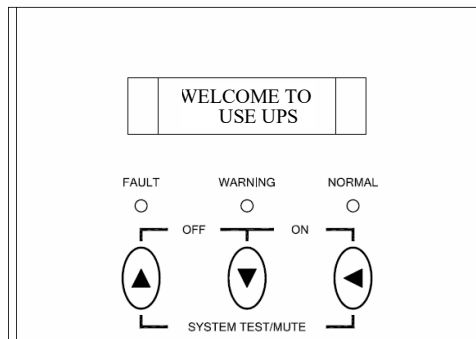
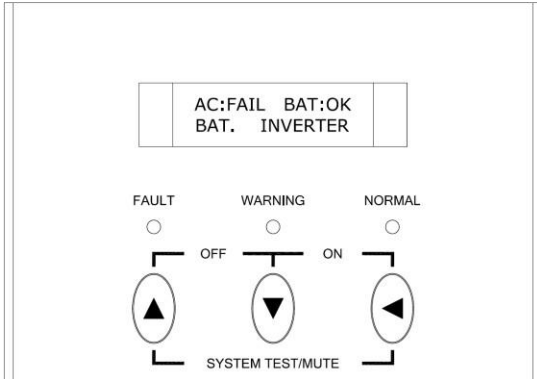

Figure 5-2 LCD Display

4. By pressing the UPS ON/OFF Control Key and the LCD Select Down key simultaneously for 3 seconds until the buzzer beeps twice, the UPS will start up and the Normal LED will illuminate to indicate that the power is flowing from the inverter to the load.
5. When the LCD Select Down-key and the LCD Select Up-key are pressed simultaneously for 3 seconds until the buzzer beeps twice, the inverter will turn off and the UPS will enter standby status (LCD screen illuminates and Normal LED is blinking) until the AC source is disconnected.

5.2.1.3 Status Menu



5.2.1.4 Voltage Menu

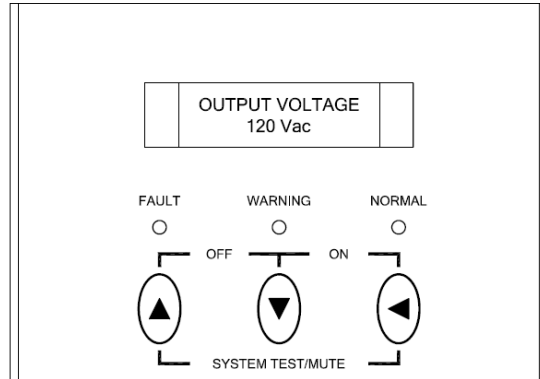
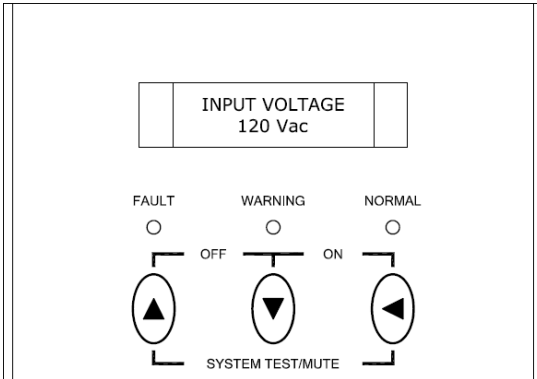

5.2.1.5 Frequency Menu

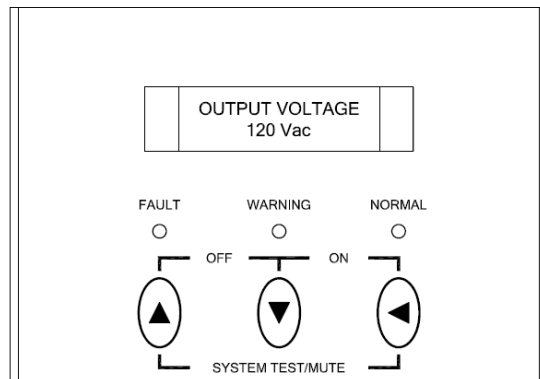
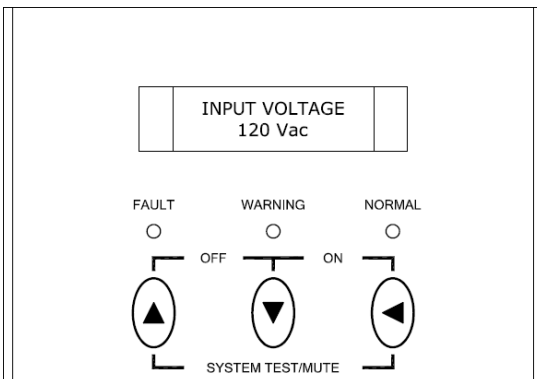

5.2.1.6 Battery Status Menu

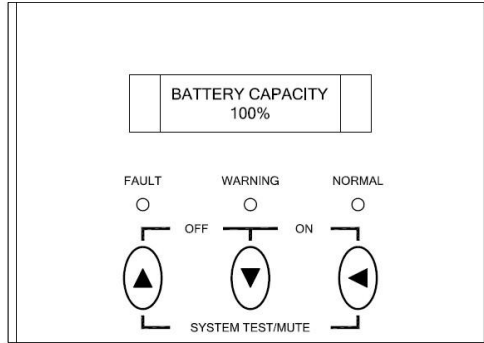
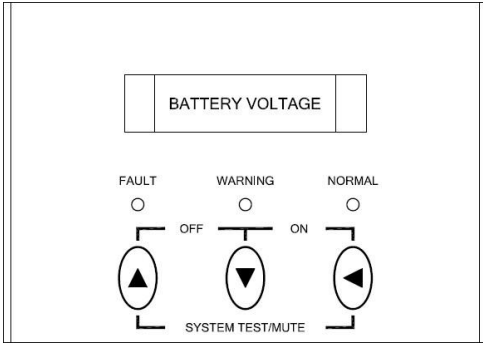

5.2.1.7 V Output Power Menu

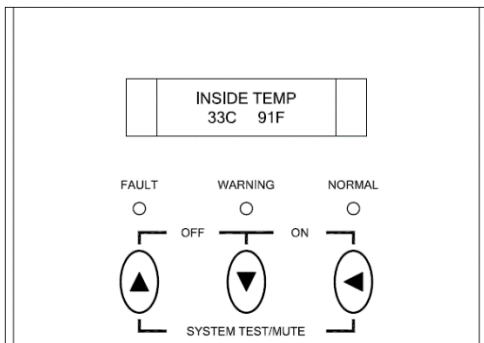
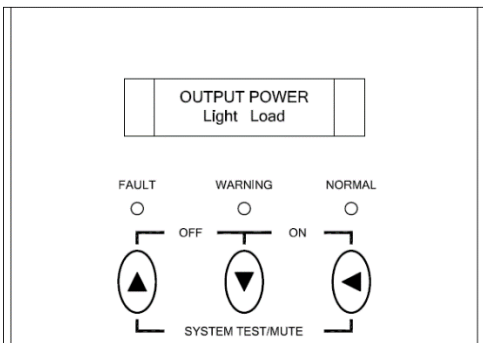

5.2.1.8 Temperature Menu

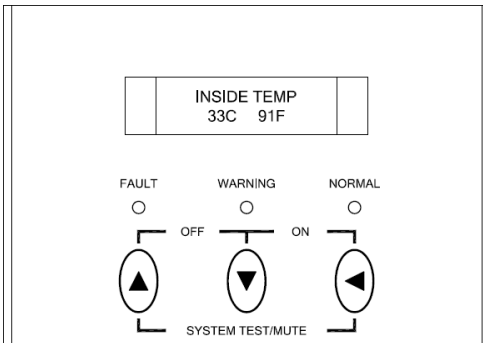

5.2.1.9 History Record Menu

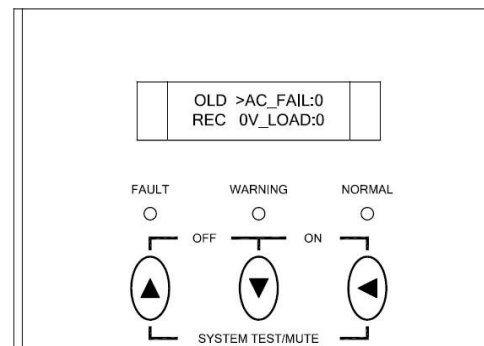
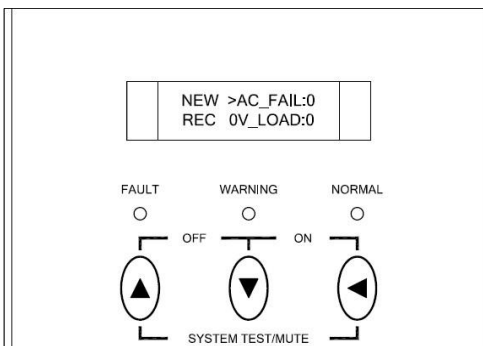

5.2.1.10 Bypass Range Set Menu

- a. To protect the load, the function of bypass auto-transfer is activated only when the AC main voltage is within the range of LO (low) and HI (high). In this screen, press the ON/OFF Control key to enter the following steps for the LO/HI voltage setting:

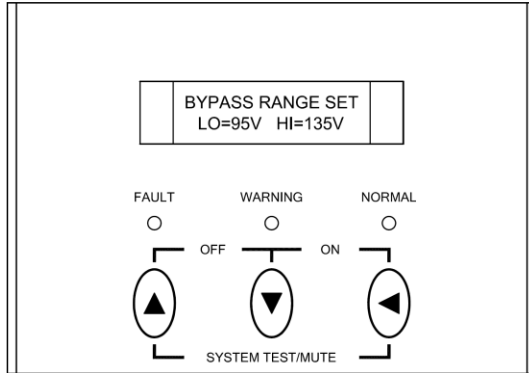

- b. The cursor (→) will appear to indicate the selected item. Press the ON/OFF Control key to find the LO or HI range display.

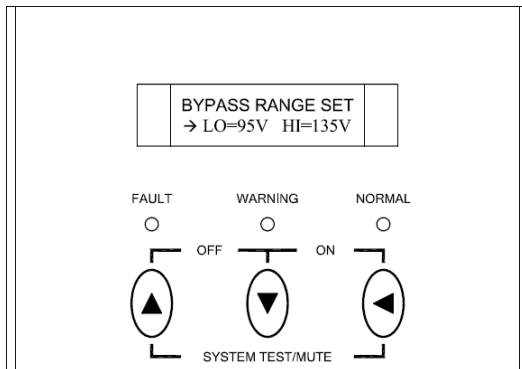

- c. Use the Up or Down key to adjust the voltage (1V for every press) to the desired setting.
- d. Once the value is confirmed, press the ON/OFF Control key again to save the data:

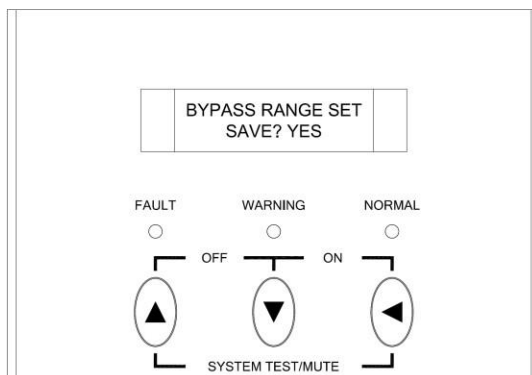

5.2.1.11 Output Voltage & Frequency Adjustment Menu

- Press the ON/OFF Control key to set the output voltage or frequency.
- The cursor (□) appears to indicate the selection of output voltage or frequency.

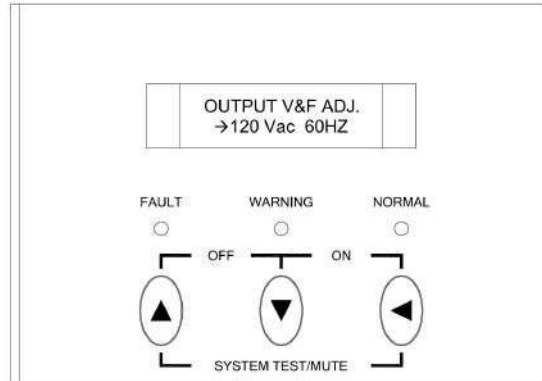

- Use the Up or Down key to adjust the output voltage to 220V, 230V or 240V for 220V systems or 100V, 110V, 115V, or 120V for 120V systems. The output frequency can be set to 50Hz or 60Hz.

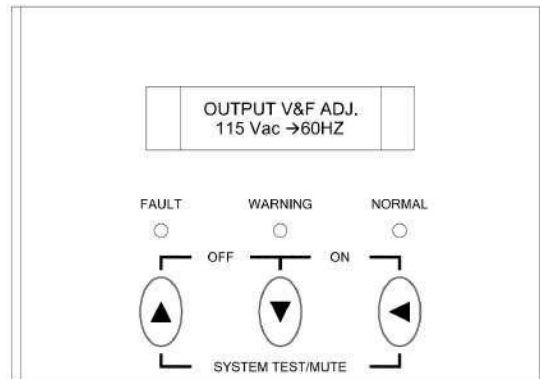

- Once the correct voltage or frequency is selected, press the ON/OFF Control key again to save the data.

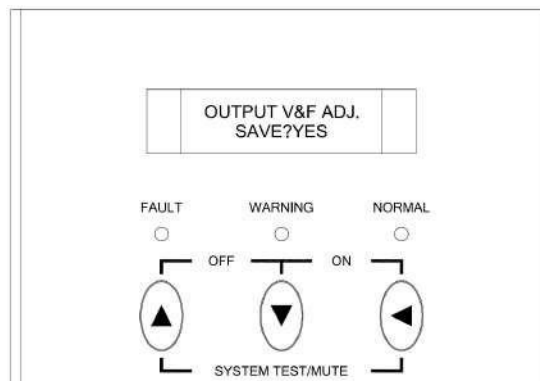

5.3 Communication

5.3.1 Communication interface

The communication interface (DB9 port) on the back of the UPS may be connected to a host computer to provide the following external control:

1. **Supply dry contact function to the UPS using software such as Megatec RUPS, which communicates with the computer by supplying a simulation of relay closure. Its major functions include:**
 - **Broadcasting a warning when power fails**
 - **Closing any open files before the battery is exhausted.**
 - **Turning off the UPS.**

2. **Supply RS-232 interface for monitoring software such as Megatec RUPSII or UPSilon 2000. RS-232 interface can also be used for USB monitoring via RS232 to USB Cable, while utilizing the same monitoring software.**

The UPS communicates with the computer by sending an RS-232 data streams to one of the serial ports, which allows the user to monitor the following parameters:

Input Voltage: Indicates the present input voltage to the UPS system when power is present.

Output Voltage: Indicates the present output voltage of the UPS.

Battery Voltage: Indicates the present DC voltage of the UPS battery.

Temperature: Indicates the actual temperature inside the UPS.

3. DB9 Interface Connector PIN Assignment

PIN 2: RS232 RXD	
PIN 3: RS232 TXD	
PIN 5: GND	
The other pins have no function	

5.4 FRU Replacement

Some components can be replaced by qualified factory-trained service personnel only. These components are referred to as Field Replaceable Units (FRUs).

For ordering the replacement parts from the factor email service@800pwrsrv.com and provide the unit's Serial No. from the Start-Up label located on the right front door. Replacement parts must be replaced by certified factory-trained service personnel only.



Electrostatic Sensitive: Circuit boards and IGBTs contain Electrostatic Discharge Susceptible (ESDS) components. Handle and package ESDS devices in accordance with JEDEC standard JESD625-A. Use a grounded ESD wrist strap when handling the devices and circuit boards. Always package components and circuit boards in static-dissipative plastic bags before transporting even if a device has failed. Failure to do so could result in further damage, complicating repair and failure analysis.

Chapter 6. Troubleshooting

Topics:

^ *Troubleshooting (page 45)*

This chapter describes typical troubleshooting steps.

6.1 Troubleshooting Chart

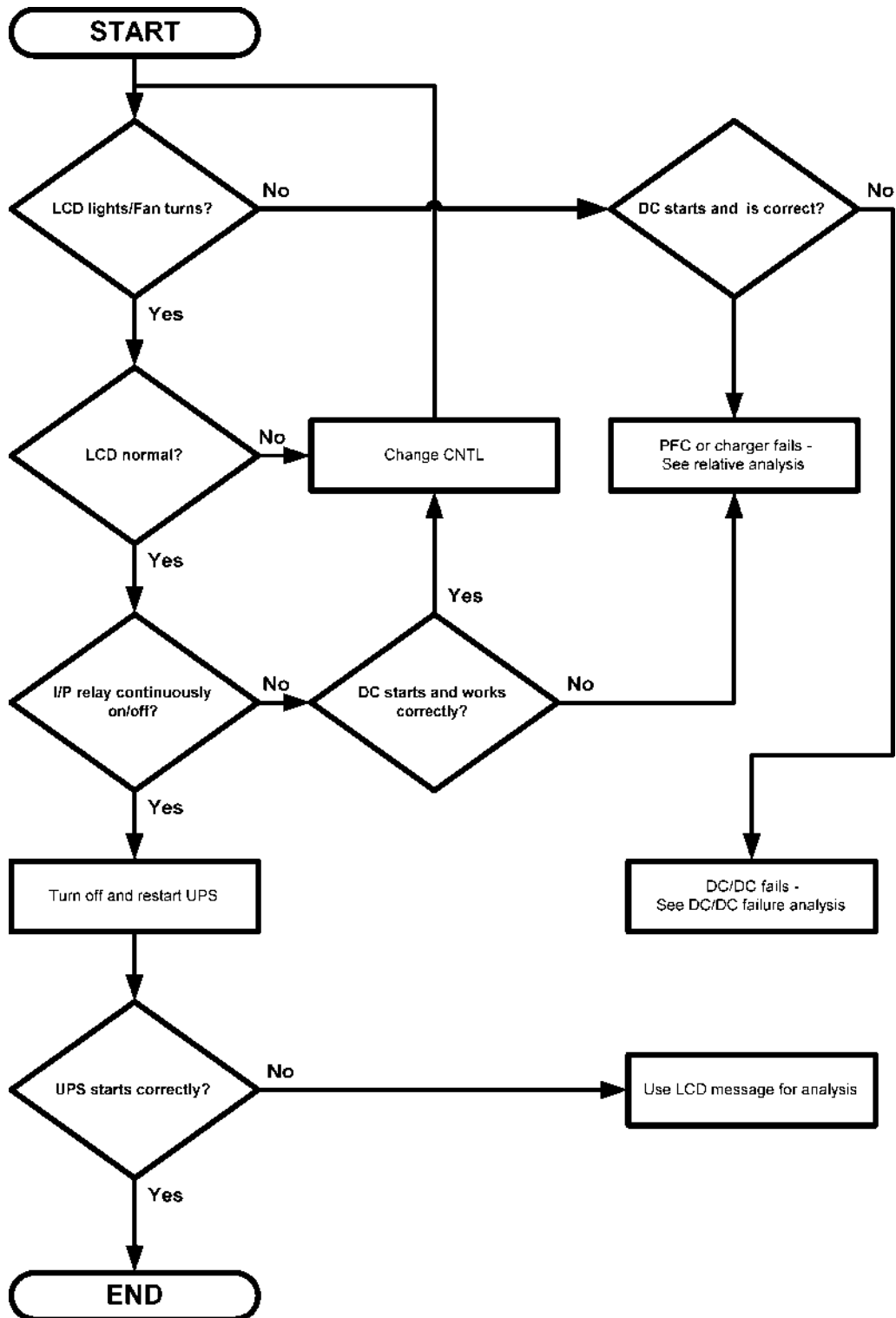

6.2 Unit Status & Actions

The following guidelines may be helpful for problem resolution.

Unit Status	Action
AC utility power is normal. UPS is running normally, but the battery capacity is low, and the alarm beeps once every second battery is low.	The charger may have failed – Replace the Charger Board.
AC utility power is normal. The output load is supplied through a bypass of the AC utility. The Fault LED illuminates, and the alarm sounds continuously.	Contact your agent for service.
AC utility power is normal, but the UPS is overloaded. The Warning LED is illuminated, and the alarm beeps every second.	Reduce the critical load on the UPS to its rated capacity (The unit's load capacity can be found on the nameplate attached to the door of the UPS).
AC utility power is normal, but the UPS is overloaded up to 125%. The Warning LED does not fade out and the alarm beeps at ½-second intervals.	Reduce the critical load on the UPS to its rated capacity (The unit's load capacity can be found on the nameplate attached to the door of the UPS).
UPS is supplying normal AC utility power via the bypass mode. The output power is more than 150% and the Warning LED is illuminated while the alarm sounds continuously.	Reduce the critical load on the UPS to its rated capacity (The unit's load capacity can be found on the nameplate attached to the door of the UPS).
AC utility power fails. The load is supplied by battery power and the alarm sounds every 4 seconds.	If AC utility power fails, reduce the less-than-critical load as soon as possible to extend the backup time. If the measurement shows that AC utility power is present on the input, check the rated input to verify that it is within specifications.
AC utility fails. UPS is in battery backup mode and battery power is approaching discharge. The buzzer alarm beeps every second.	UPS will shut down automatically when the battery reaches its discharge limit. To avoid data loss, save your data without delay.
AC utility power fails, and the battery drains below the minimum level. UPS has shut down automatically.	The UPS will automatically restart when the AC utility power is restored. If the AC utility power failure exceeds 6 hours, it is important to follow the storage instructions in Section 4 of this manual.

Appendix A – Options

This appendix provides detailed information about the options available for the Single-Phase Lighting Inverter.

A.1 Auxiliary Output Circuit Breaker, 1pole, 20amp (max. 12)

These 1-pole, 20A circuit breakers are designed to protect customer circuits and are offered at a maximum of twelve auxiliary circuit breakers per unit.

Offered in the following options:

- **Normally ON C.B. option**
- **Normally OFF C.B. option**
- **Normally OFF C.B. option with Time Delay**

A.2 MBS (Maintenance By-pass Switch – manual)

- To move from UPS mode to Bypass mode
 1. Turn off the battery breaker.
 2. Move the manual bypass switch to the BYPASS position.
- To move the Bypass mode to UPS mode
 1. Turn off the battery breaker.
 2. Move the manual bypass switch to the UPS position.
 3. Turn on the battery circuit breaker for normal operation.

A.3 Auxiliary Transient Voltage Surge-Suppressor (TVSS)

The TVSS contains energy-absorbing components designed for specific line configurations. If protection components become damaged by absorbed transients, the device shows a reserve flag that indicates a need for replacement. The unit remains operational but without surge protection.

A.4 AS400 Relay Card

Used to provide a potential free relay contact interface for those industrial control applications that require dry contact signals, a conveniently located terminal block is provided for hardwire connection as shown below:

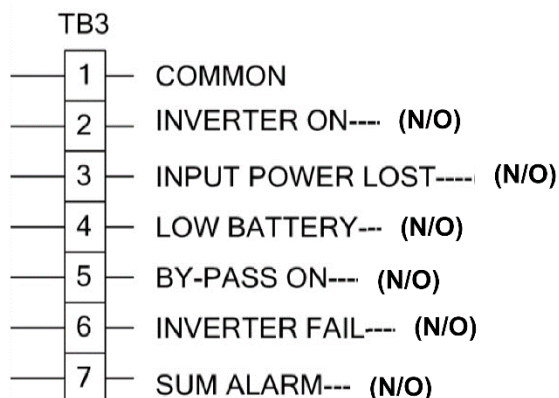

A.5 Floor Mounting Brackets

This floor-mountable unit can be re-configured with two additional brackets at the bottom sides of the machine.

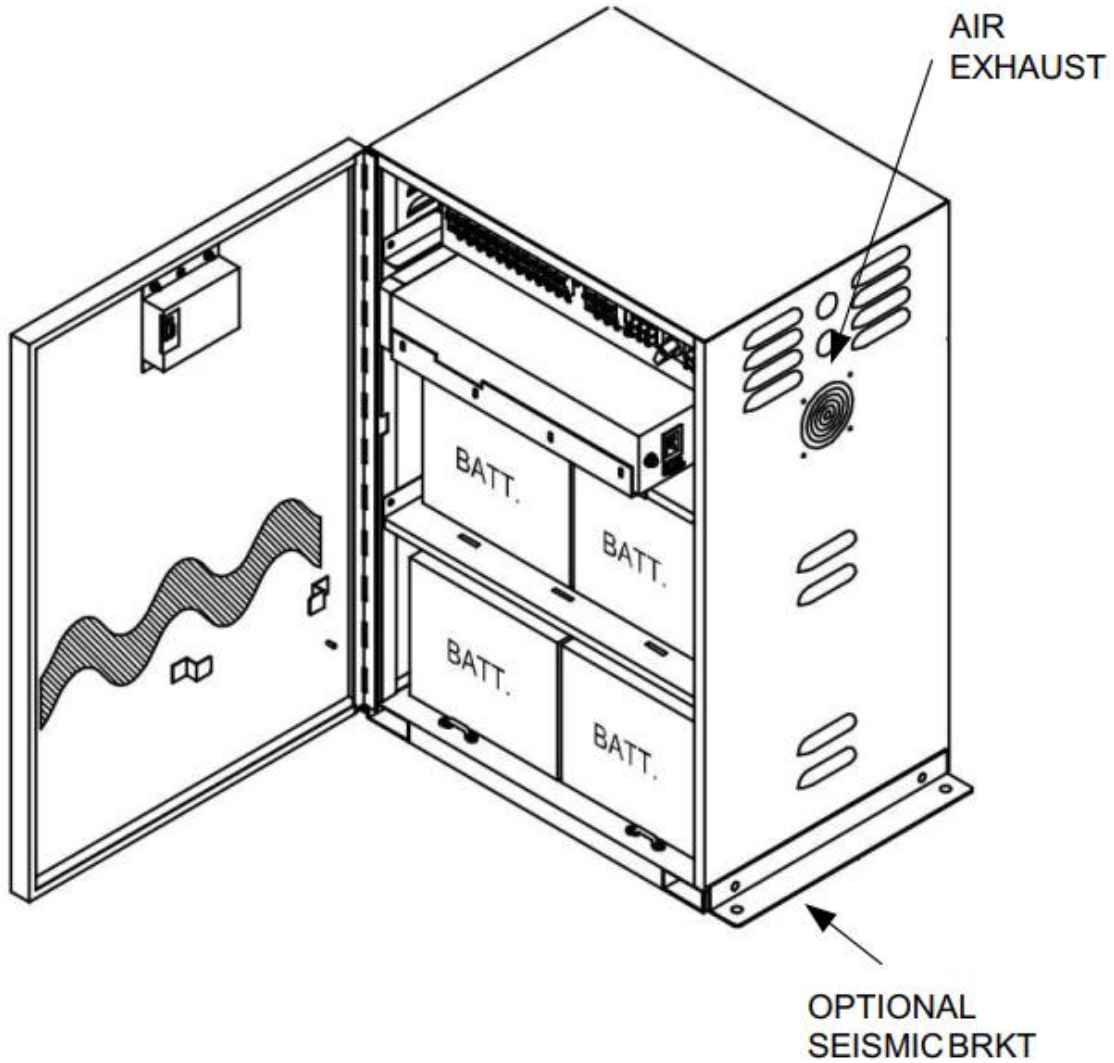

Figure A-1. Seismic Bracket Isometric Drawing

A.6 RS232 or USB Monitoring via RS232 Communication Interface.

A.6.1 Communication (RS232)

This option allows the communication of the unit as mentioned in Section 5.3 via an RS232 Cable. For the location, see Figure A-2. Follow steps in section A.8.2.1 in the next pages on how to install monitoring software.

A.6.2 Communication (USB)

This option allows the communication of the unit as mentioned in Section 5.3 via an RS232 to USB Cable. For the location, see Figure A-2. Follow steps in section A.8.2.1 in the next pages on how to install monitoring software.

A.7 SNMP/WEB Card or AS400C W/ Relay Card

This option allows the communication of the unit as mentioned in Section 5.3 via an SNMP Net agent9-Y Mini Go USB Card. For the location, see Figure A-2.

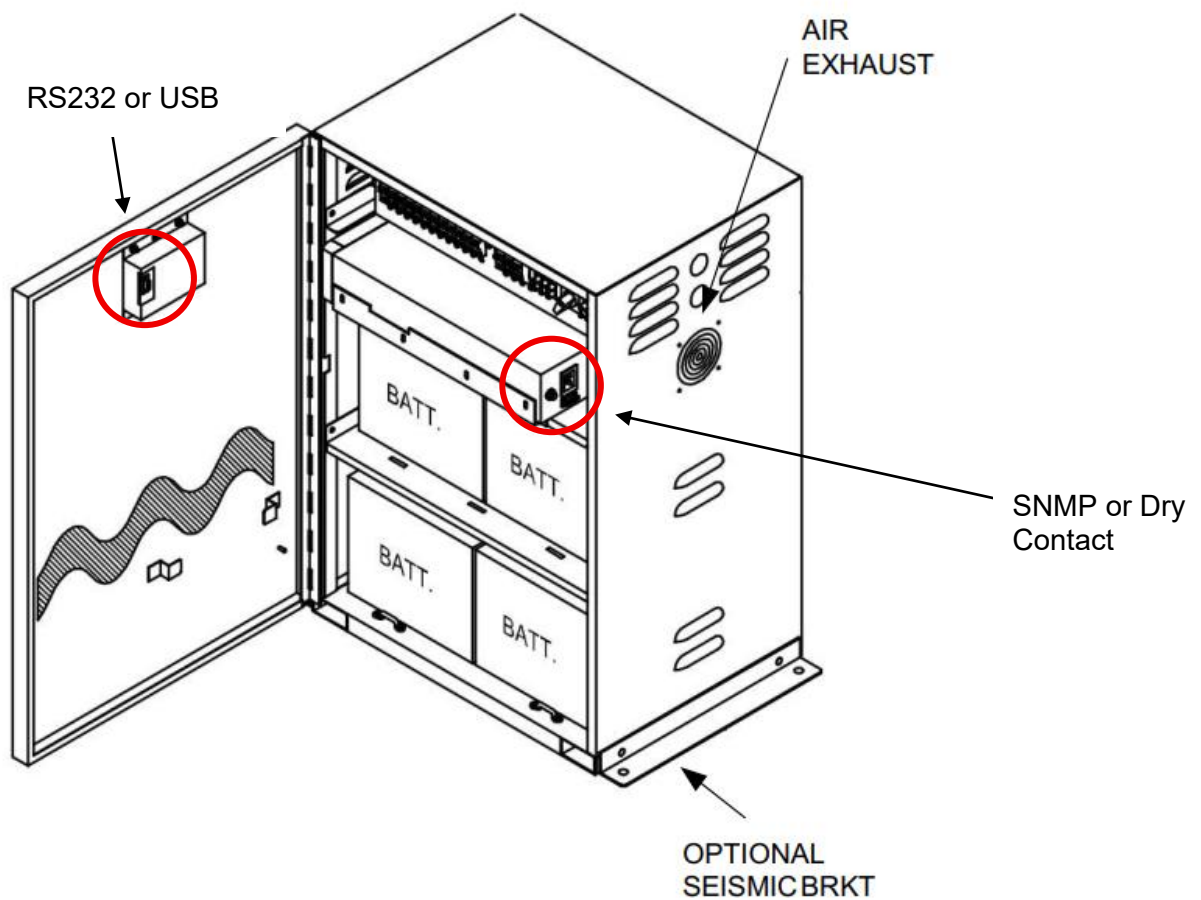

Figure A-2. Location of SNMP, AS400 Dry Contacts, RS232, & USB Options

A.8 Optional Battery thermal runaway control via shutting off the charger, auto restart, battery exerciser, and event logger.

A.8.1 BATTERY THERMAL RUNAWAY CONTROL

Protects in case of over temperature (+40° C) in the battery compartment by shutting off the charger and provides an alarm “BATT OVER TEMP”. on LCD. will resume charging when the temperature returns to normal.

“BATT OVER TEMP”. on LCD. will resume charging when the temperature returns to normal.

A.8.2 Battery exerciser and event logger

A.8.2.1 (Software Installation)

1. Go To: <http://java.com/download>

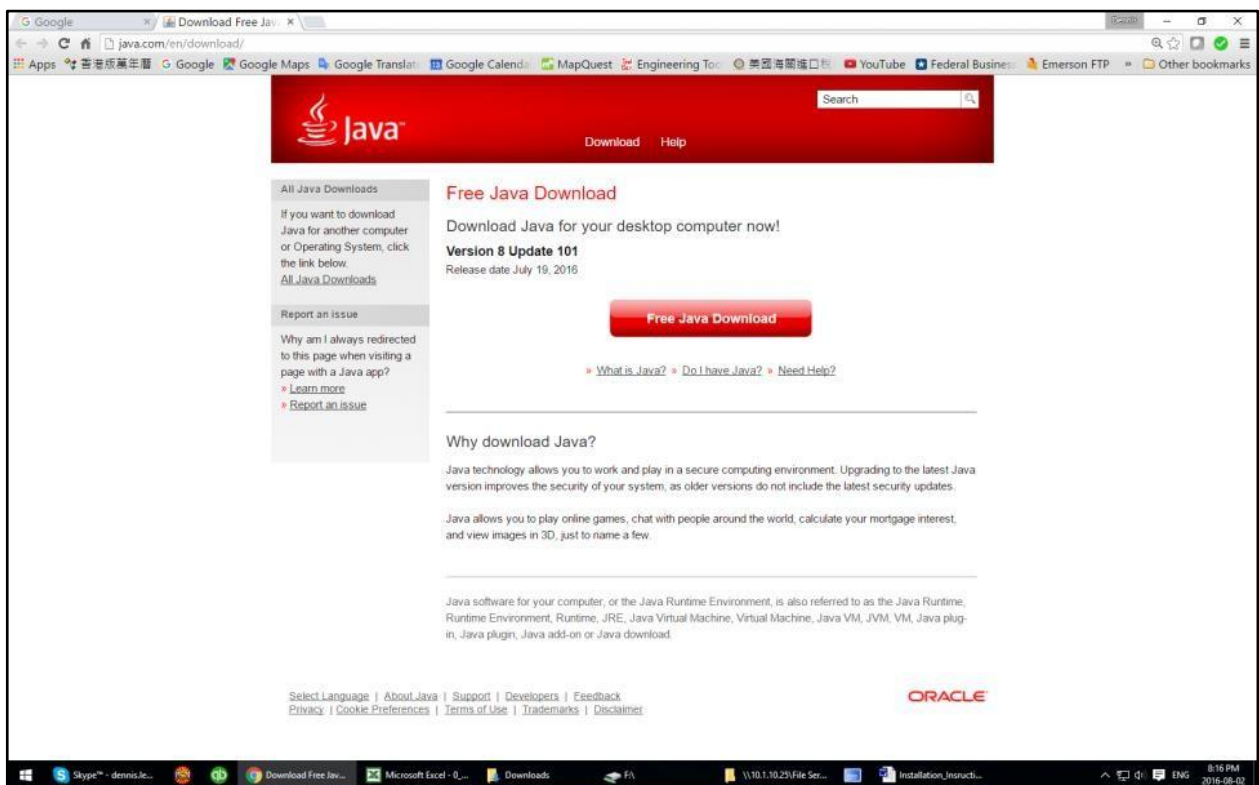

2. Download and install JAVA JRE program. Or Save from JRE Folder to install the program.

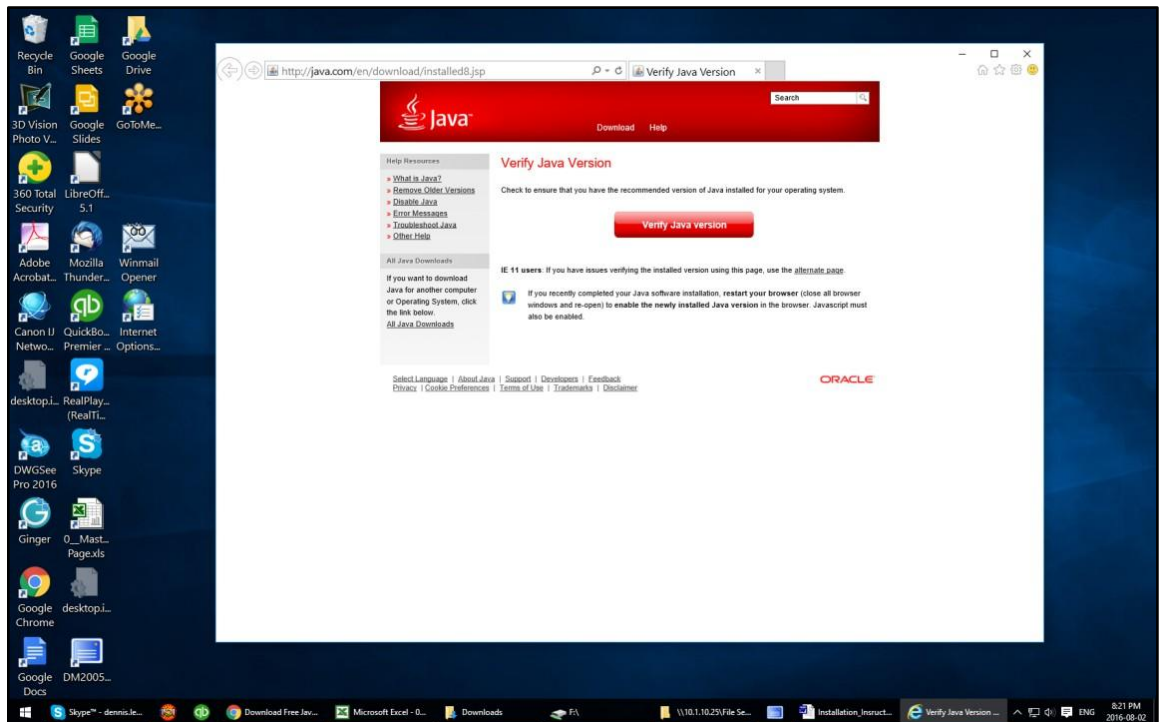
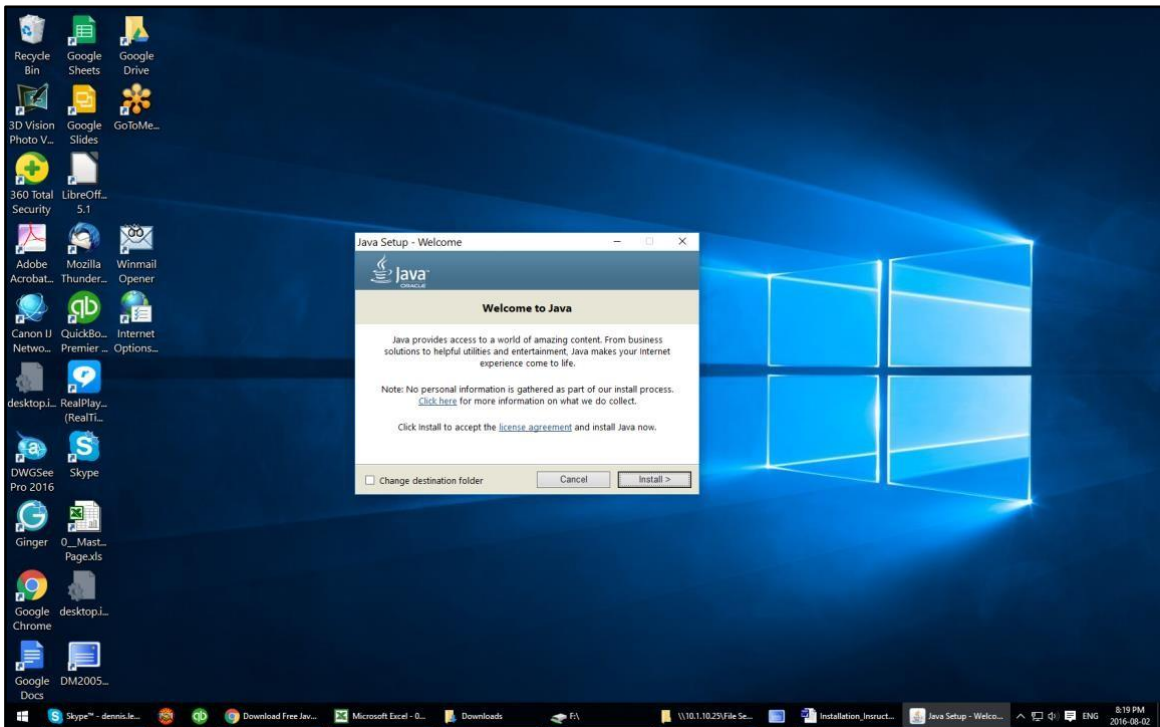

Appendix A – Options

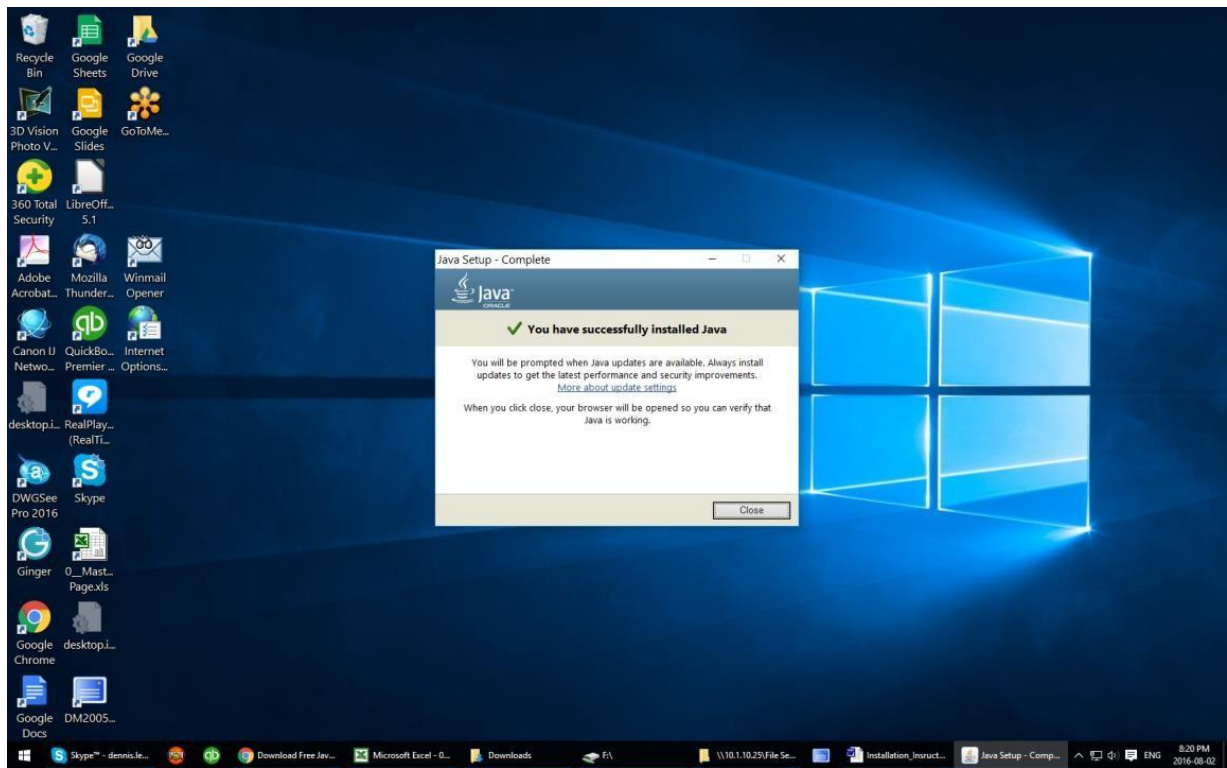
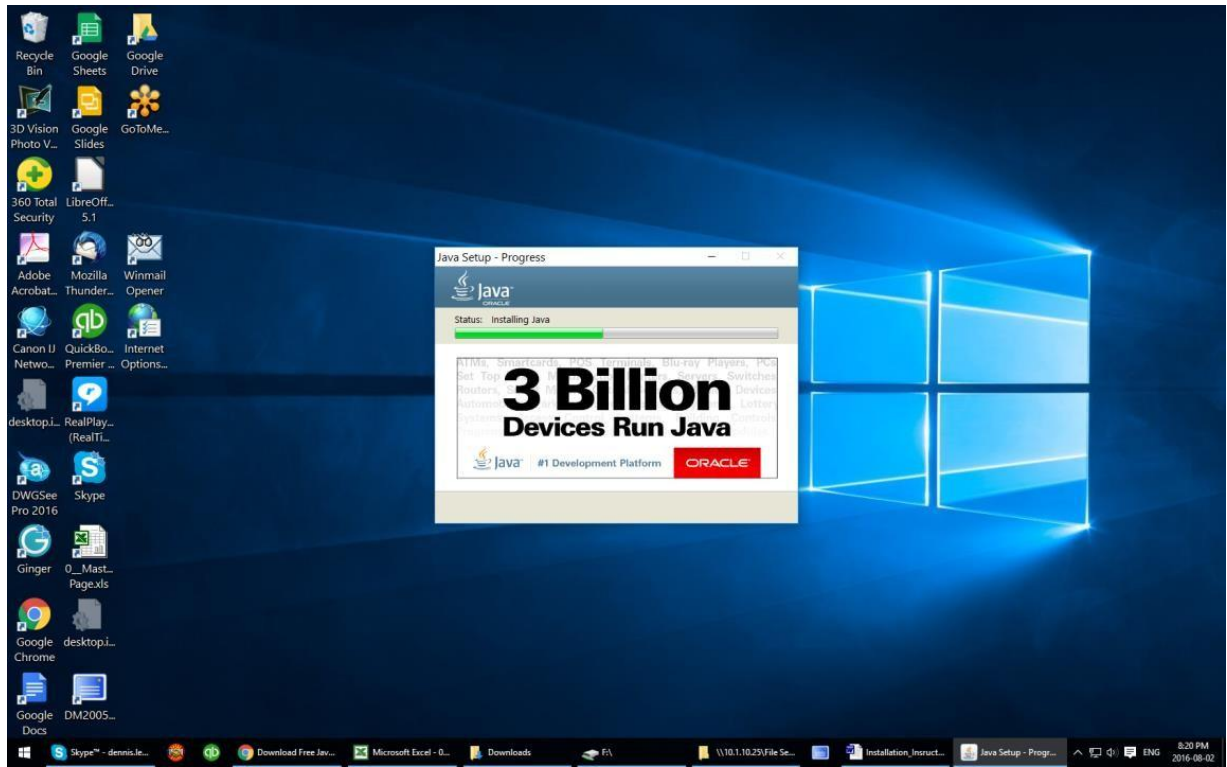

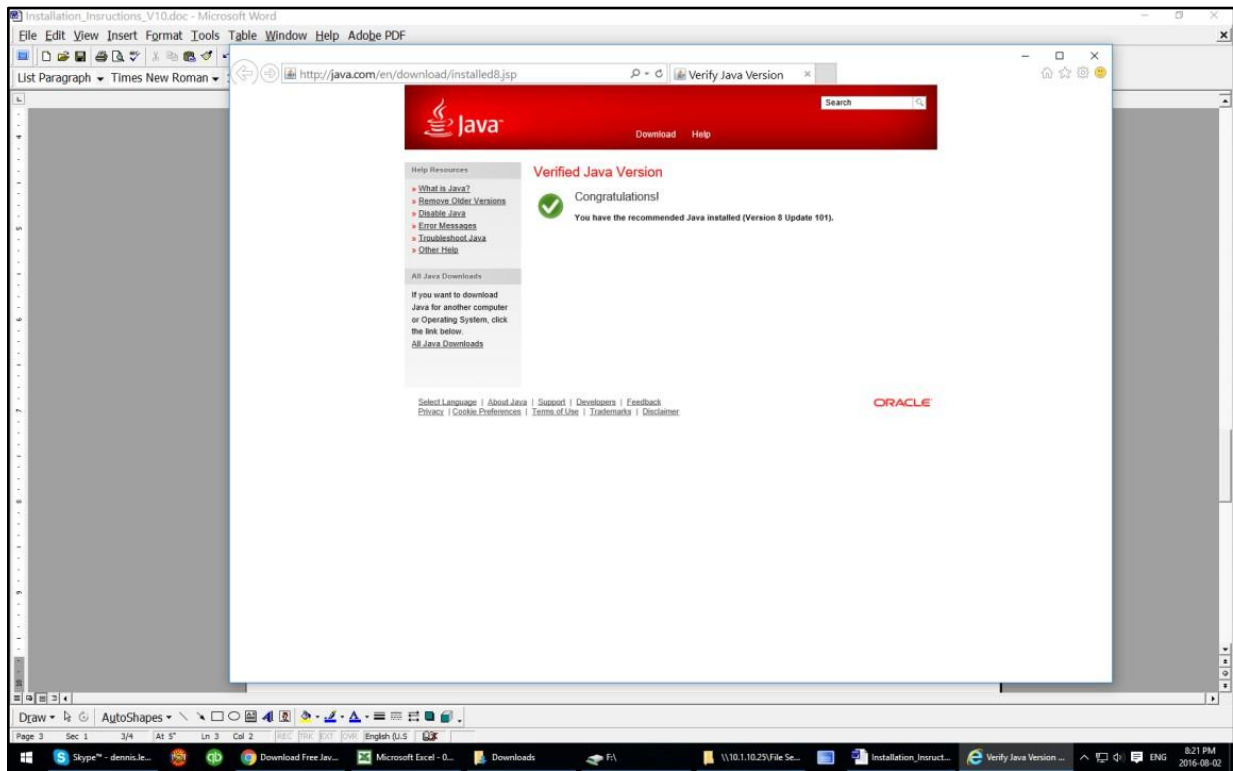

3. If your computer already have the JAVA JRE installed, then please skip this process.
4. After the JAVA JRE Program has been installed, please click and execute the UL924 UPS Battery Exerciser Program “UPSBatteryTest.exe”



Appendix A – Options

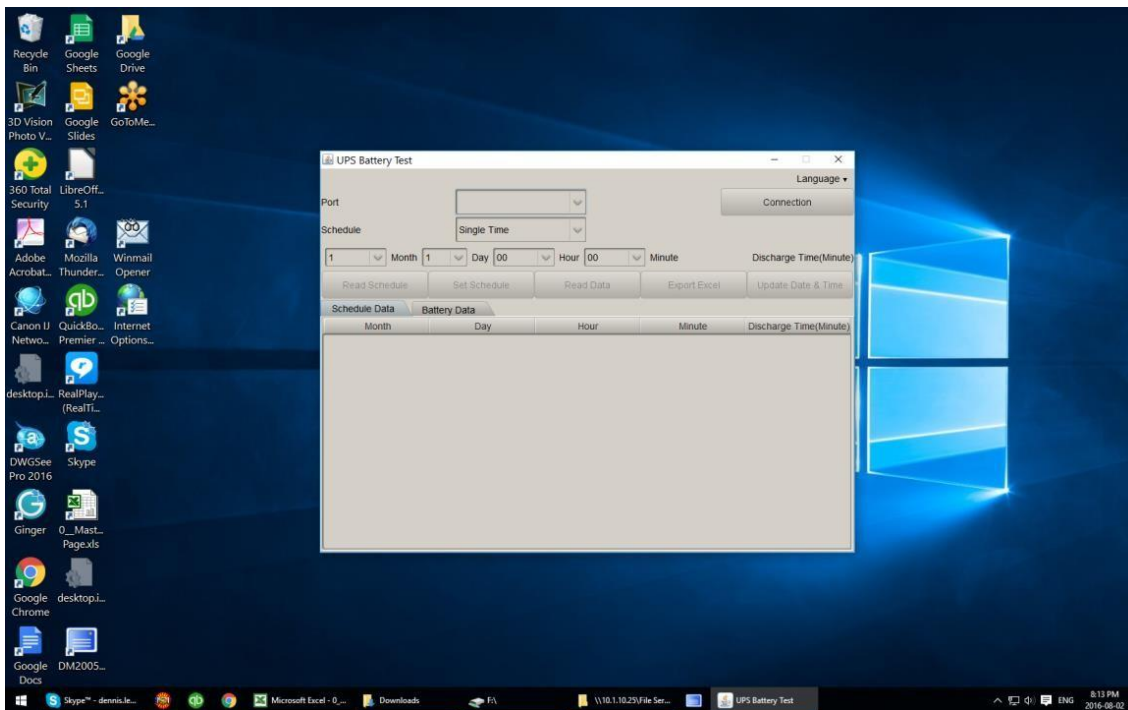
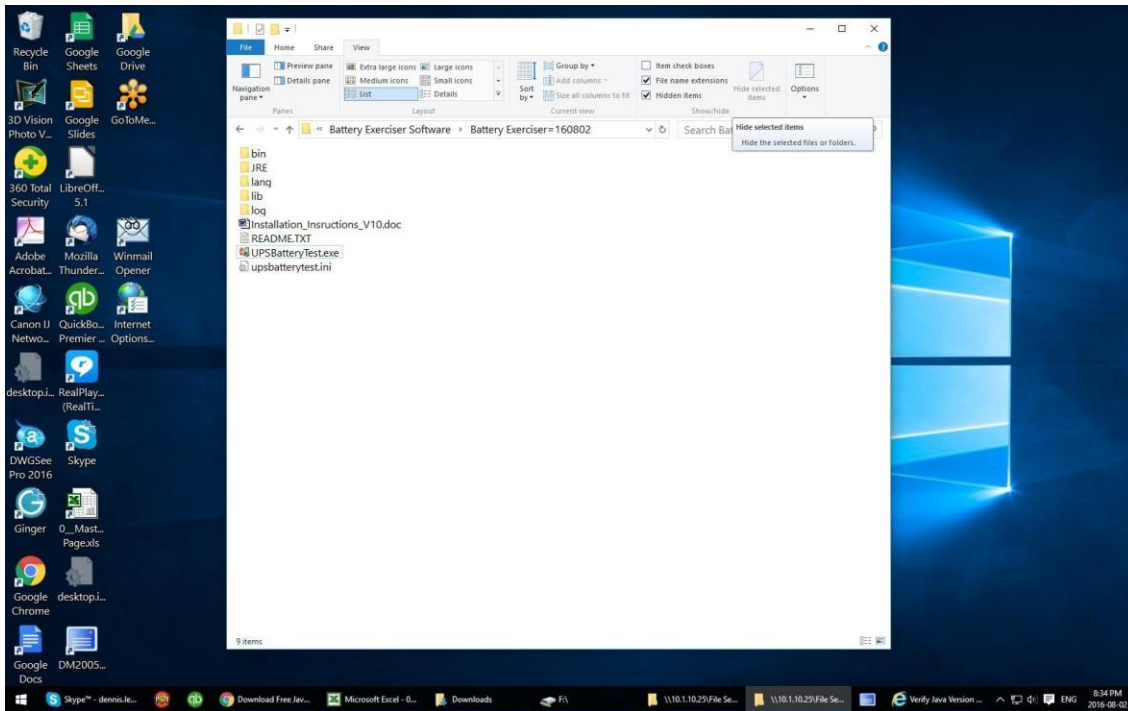

Installation Completed.

A.8.2.2 Introduction

- The Mini Power Wave Lighting Inverter provides a Battery exerciser (*SELF TESTING) capable of testing and can be set between 1 ~ 255 Minutes monthly and yearly.
- It will provide self-diagnostic detection of a non-functional feature during a self-testing /self-diagnostic routine.
- Provides Test Data of 40 Battery Tests.
- Test Data can be exported to the following Excel File:
 - Battery Test Start Date and Time.
 - Battery Voltage at Battery Test Starting.
 - Battery Test Ending Date and Time.
 - Battery Voltage at Battery Test Ending.
 - Battery Test Mode: Automatic or Manual.
- It can log the following events and export an Excel File:
 - Disconnection of the battery power source.
 - The battery charger is not receiving its intended charging voltage or has experienced an internal failure that inhibits its ability to provide the intended charging current to the battery.
 - 110% Overload.

A.8.2.3 Installation:

Use the RS232 Communication Interface Cable to connect the RS232 Port to the Computer's RS232 Serial Port.

Execute the UPSBatteryTest.exe in the UPS System Test Folder in Computer C:\ Drive.

- Click on [Schedule Setting](#).
- Select the Communication Port
- Click and Execute [Connection](#).

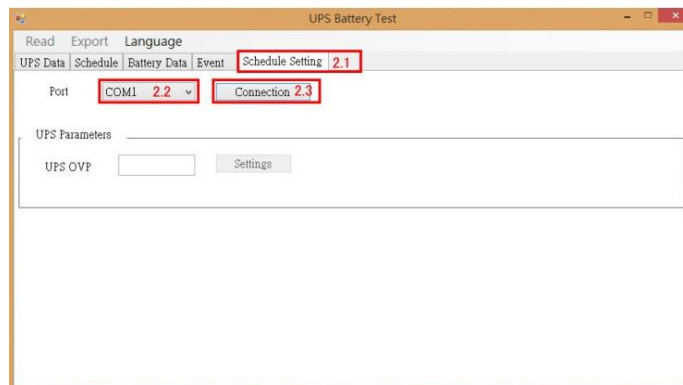

A.8.2.4 Loading Level Alarm Set Up

Users can set up the Loading Level Alarm trigger point, when loading exceeds the loading level setting point, then UPS will initiate an Alarm. This loading level alarm setting will not affect the UPS Output Overload Protection Settings.

- Click Schedule Setting.
- The displayed value is the current setting. If you want to change the setting, please change the setting value (20 ~ 100, this value represents the UPS Loading Level 20% ~ 100%).
- Then, Click the [Setting](#) under the [UPS Parameters](#).

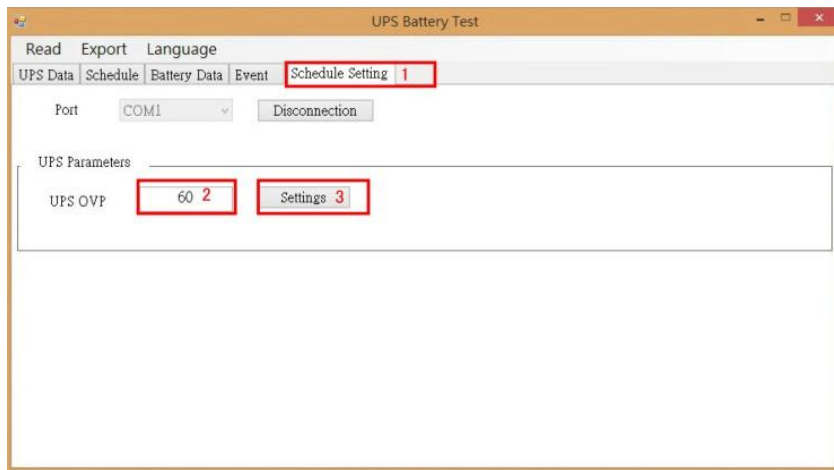

A.8.2.5 System Real-Time Information.

System Real Time Information is displayed as below:

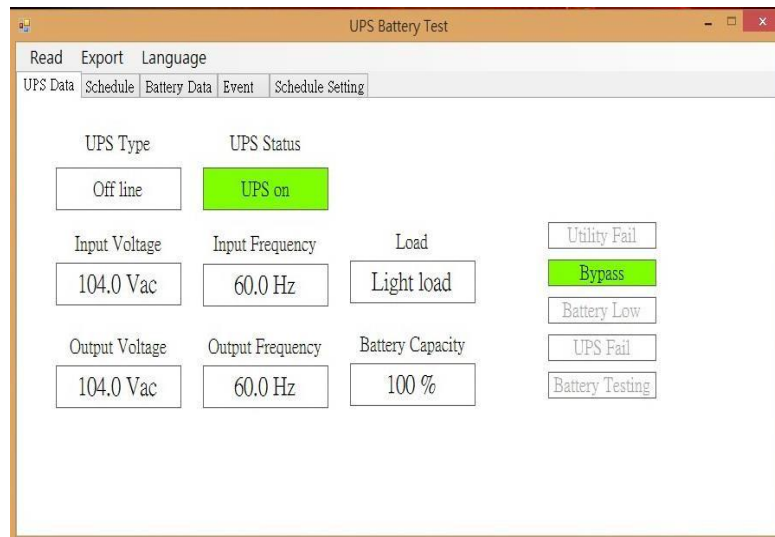

A.8.2.6 System Date and Time Set Up

When the System's date and time are not correct, click on Schedule, and then click Update Date. The UPS System's Date and Time will be synchronized with the Date and Time of the connected computer.

Note:

Before proceeding with the Update Date, first check your computer Data and Time.

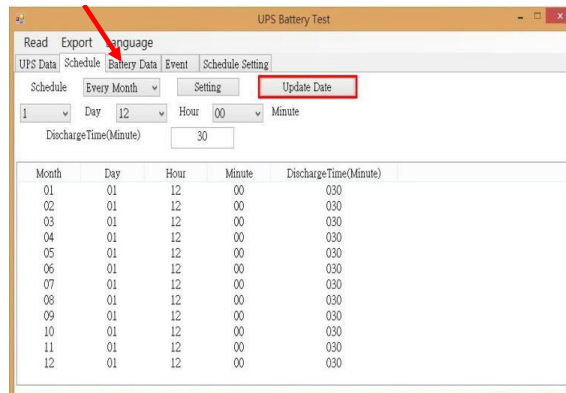

A.8.2.7 Battery Test Schedule Set Battery Test Schedule Set Up.

Battery Test Scheduling can be monthly individually set up, or one time set up 12 months.

- Select [Single Time](#) or [Every Month](#).
- Select Battery Test execution date and time, discharging duration (1 ~ 255 minutes).
- Click [Setting](#).
- Scheduling Single Time will only execute once, therefore it will replace the previous setting.

After setting completion, click to read the UPS Battery Test Schedule to make sure the Battery Test Schedule is set up correctly. Refer to the next section to read the system battery test schedule.

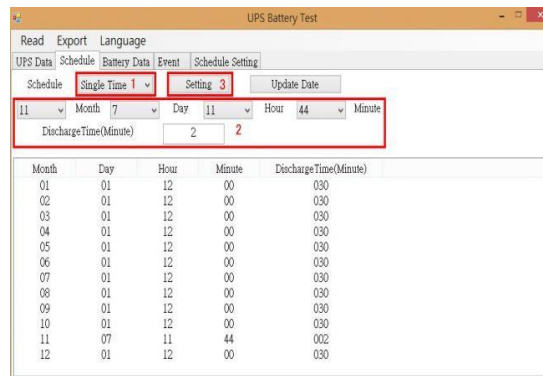

A.8.2.8 Viewing the current System Battery Test Schedule Settings Status

- Click on Read Schedule.
- The screen will display the current UPS Battery Test Schedule.

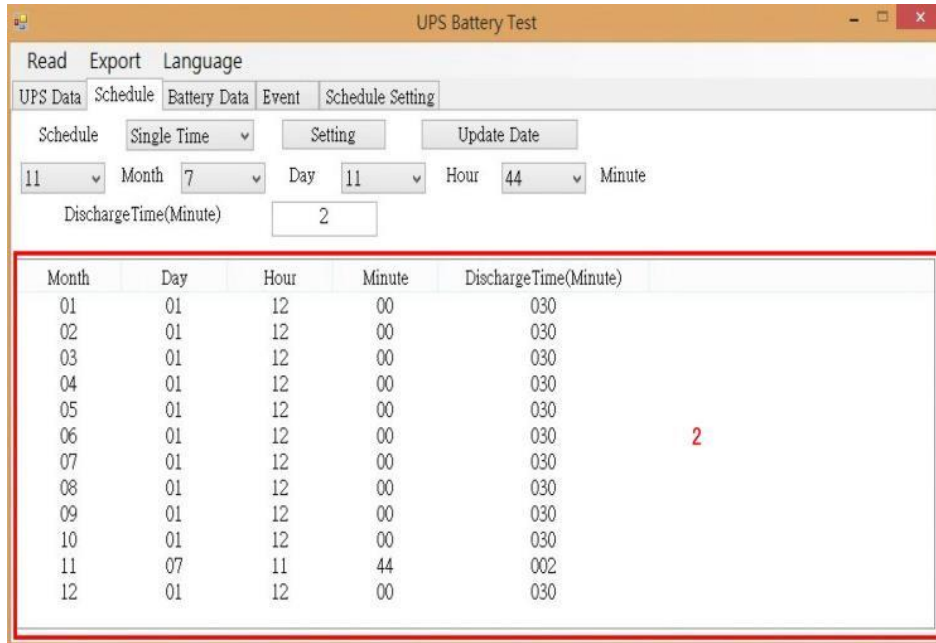
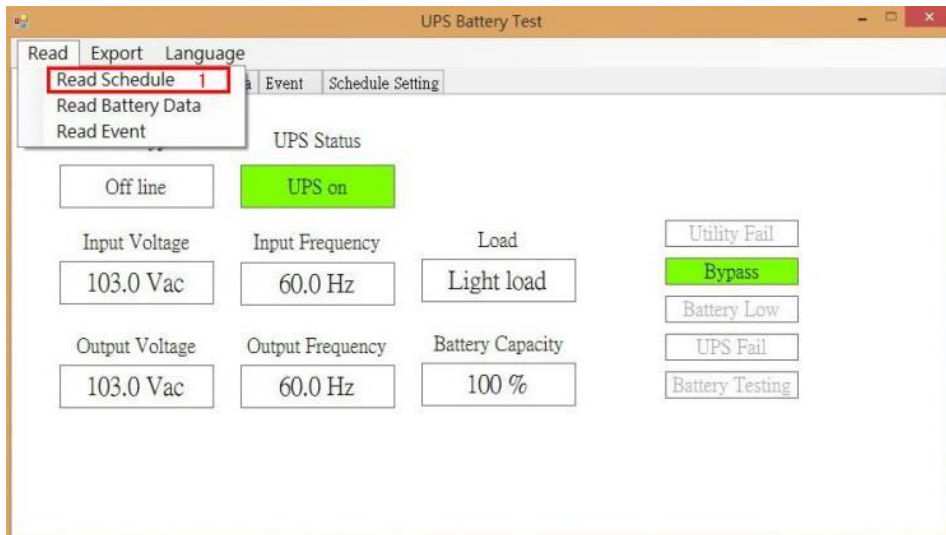

A.8.2.9 Viewing the Battery Test Historic Data:

- Click Read Battery [Data](#).
- Then Screen will display the SYSTEM Battery Test Historic Data. The system can show 40 test data string.

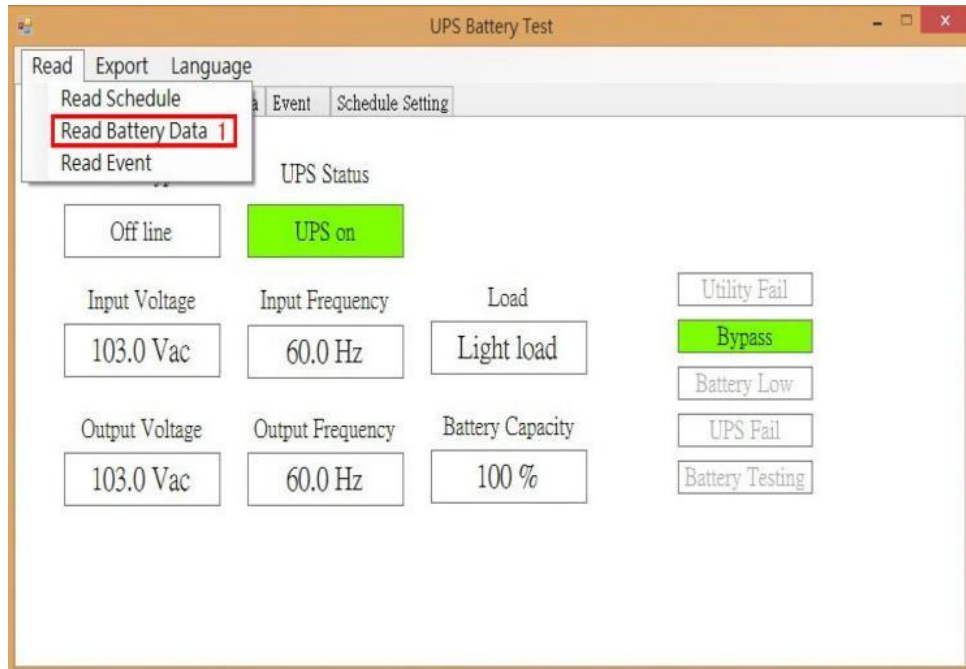

- Displayed SYSTEM Battery Test Historic Data:

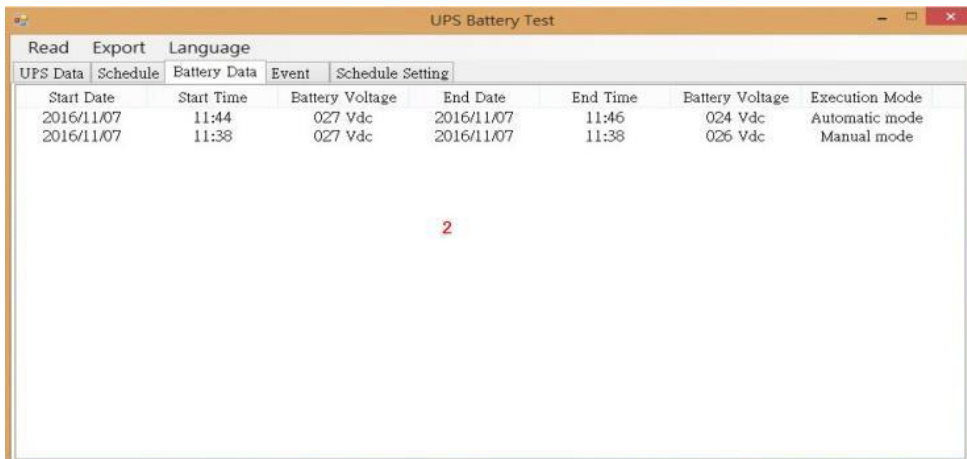

A.8.2.10 To view the system Event Log:

- Click Read Event.
- The screen will display the recorded SYSTEM Event Log. The system can record up to 40 events.

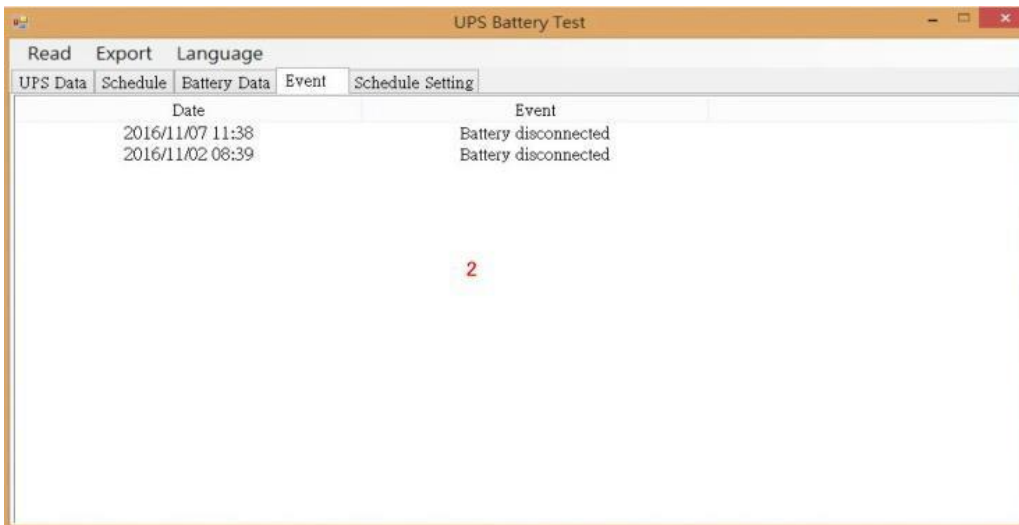
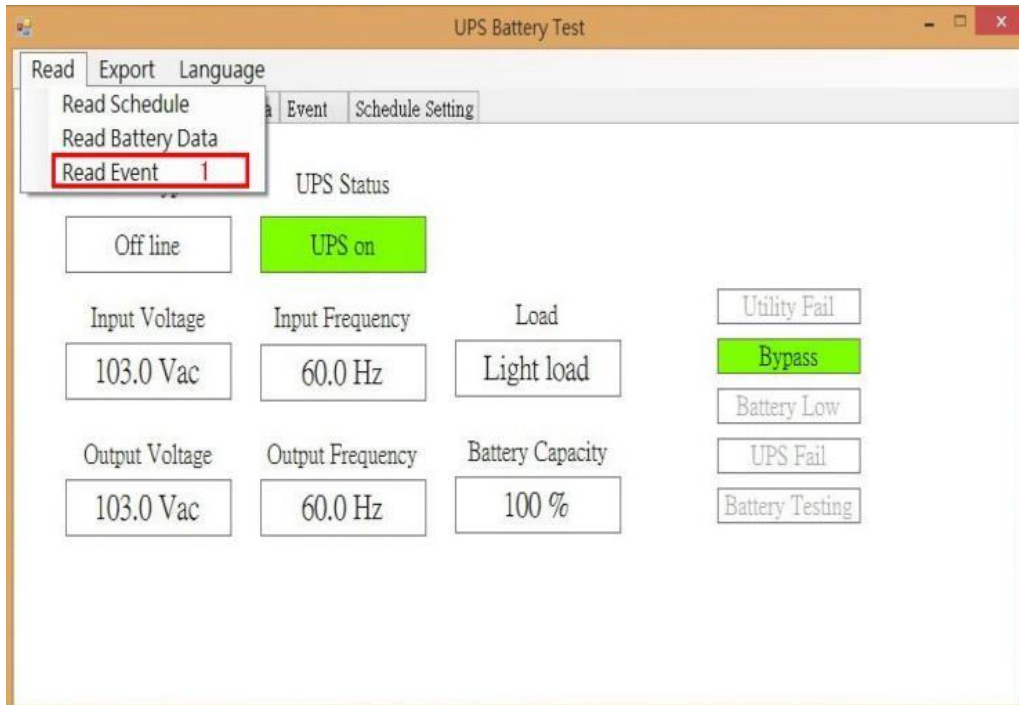

A.8.2.11 Output Historic Test Data to Excel File

- Click on [Export Excel](#), then click Battery Data
- Select the save path and destination folder to save the Excel file.

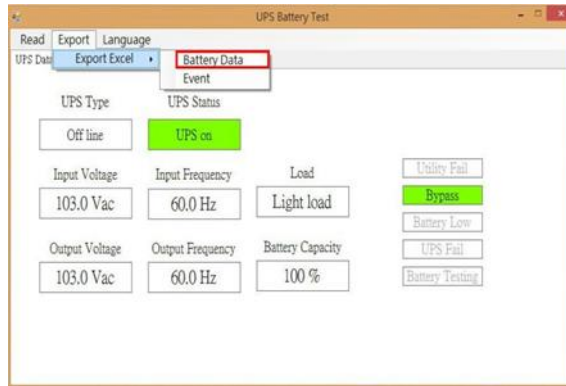

A.8.2.12 Export Event Log Data to Excel File

- Click [Export Excel](#), then click [Event](#)
- Select the save path and destination folder to save the Excel file

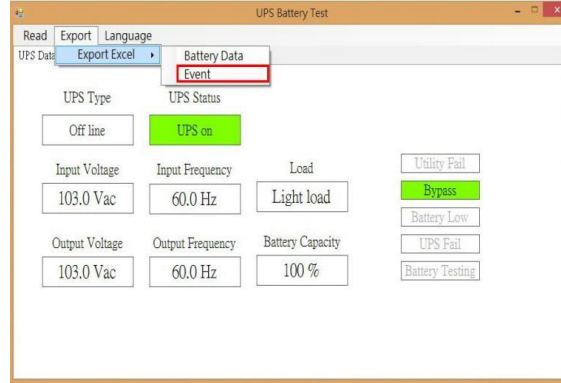

The exported Excel Event Log file content is shown below

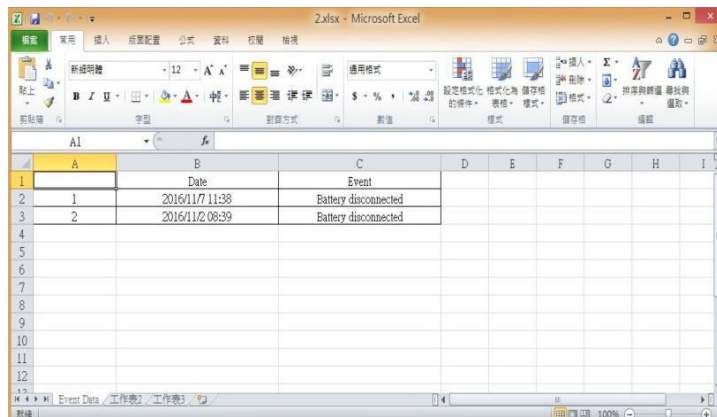

Appendix B - Specifications

This appendix provides detailed information on the electrical and physical characteristics of the Single-Phase Lighting Inverter.

Specifications for 120VVAC /277VAC									
Capacity (W)	Description	500	750	1000	1250	1500	2100	2500	2700
Input	Voltage	Single Phase 120Vac or 277Vac							
	Voltage Range	120Vac \pm 10% or 277Vac							
	Frequency	60Hz +/- 4Hz							
Output	Voltage (on battery)	Single Phase 120Vac or 277Vac							
	Voltage Range	120Vac \pm 2% or 277Vac							
	Frequency (on battery)	60 Hz +/-0.5%							
	Transfer Time	0 ms							
	Overload Recovery	Auto transfer to Inverter							
	High-Efficiency mode (AC to AC)	> 95 %							
	SYSTEM Design Technology	On-Line / Fully digitized microprocessor-controlled							
	Output Wave Form	Sine wave							
	Harmonic distortion	< 3% of T.H.D. at linear load							
Protection and Filtering	Overload Protection	125% for 1 minute and 150% for 10 seconds							
	Short Circuit Protection	Circuit breaker							
System/Display/Warning	Visual Display (LED model)	SYSTEM on(green), line-mode(green), battery mode(yellow), bypass(yellow), fault(red)							
	Visual Display (LCD model)	Input/output voltage, input/output frequency, on-line mode, backup mode, battery capacity,							
	Audible Alarm	Beep every 5 sec							
	UPS Fault	Continuous beeping sound and LCD screen							
	Communication	RS-232 Serial Port and USB							
Battery	90 min. UL924 (Eight Sealed, maintenance-free lead acid Battery)								
Dimensions	(Inches) Width x Height x Depth	23.5 X 34.25 X 18.25							
Environmental	Operating Temperature	0 - 40°C / 32 ~ 104°F							
	Storage Temperature	-20 ~ 50°C / -4 ~ 122°F							
	Audible Noise (1 meter from surface)	< 40 dBA							
	Relative Humidity	0 ~ 95% humidity, non-condensing							

Note: Due to continuous improvement, specifications are subject to change without prior notice .